

Glasbearbeitung bei Verwendung von  
Magnetdichtung Nr.20 1150 11 27 01

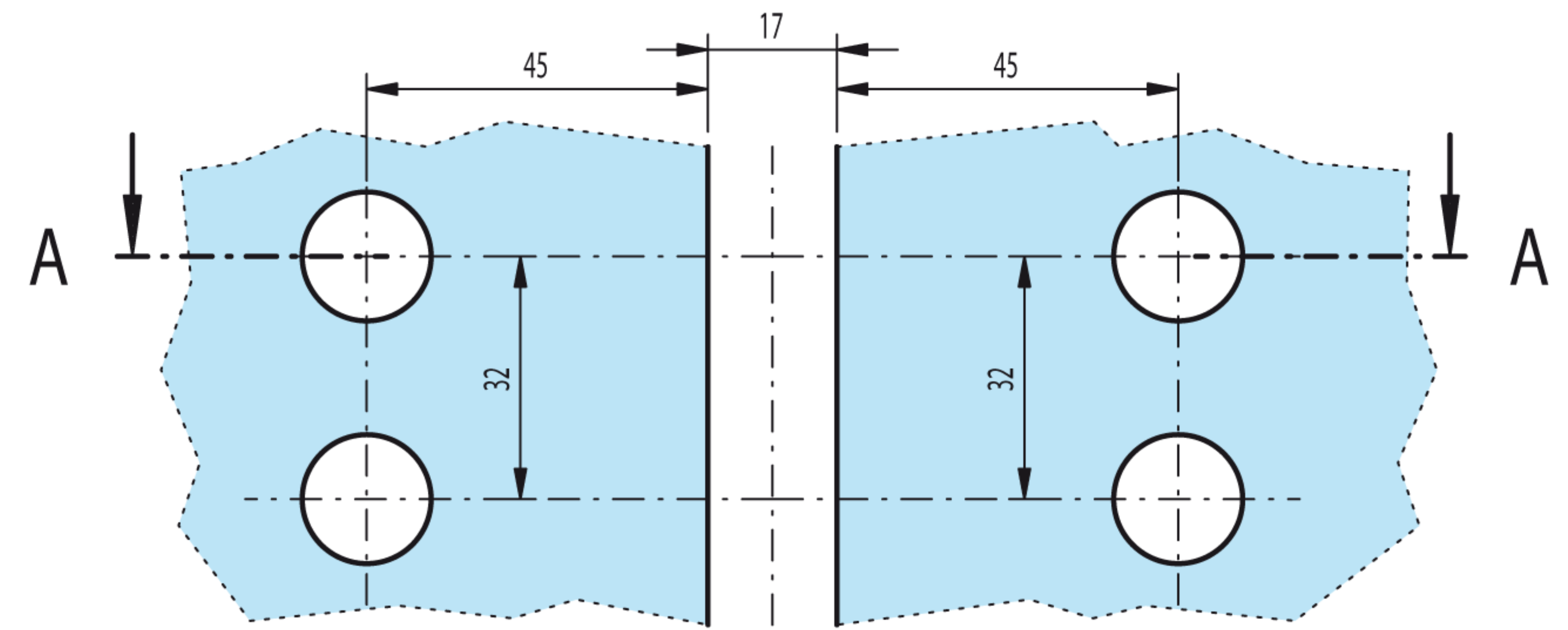

Flügelglas

Flügelglas

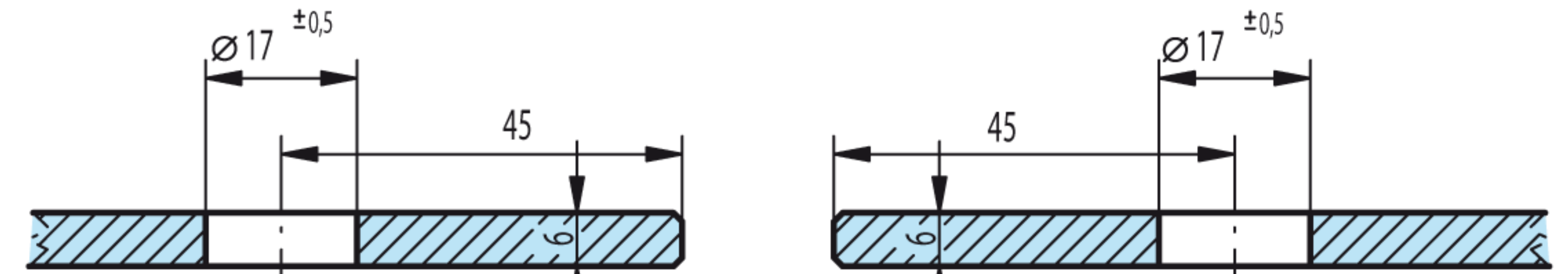

Schnitt: A-A (M1:1)

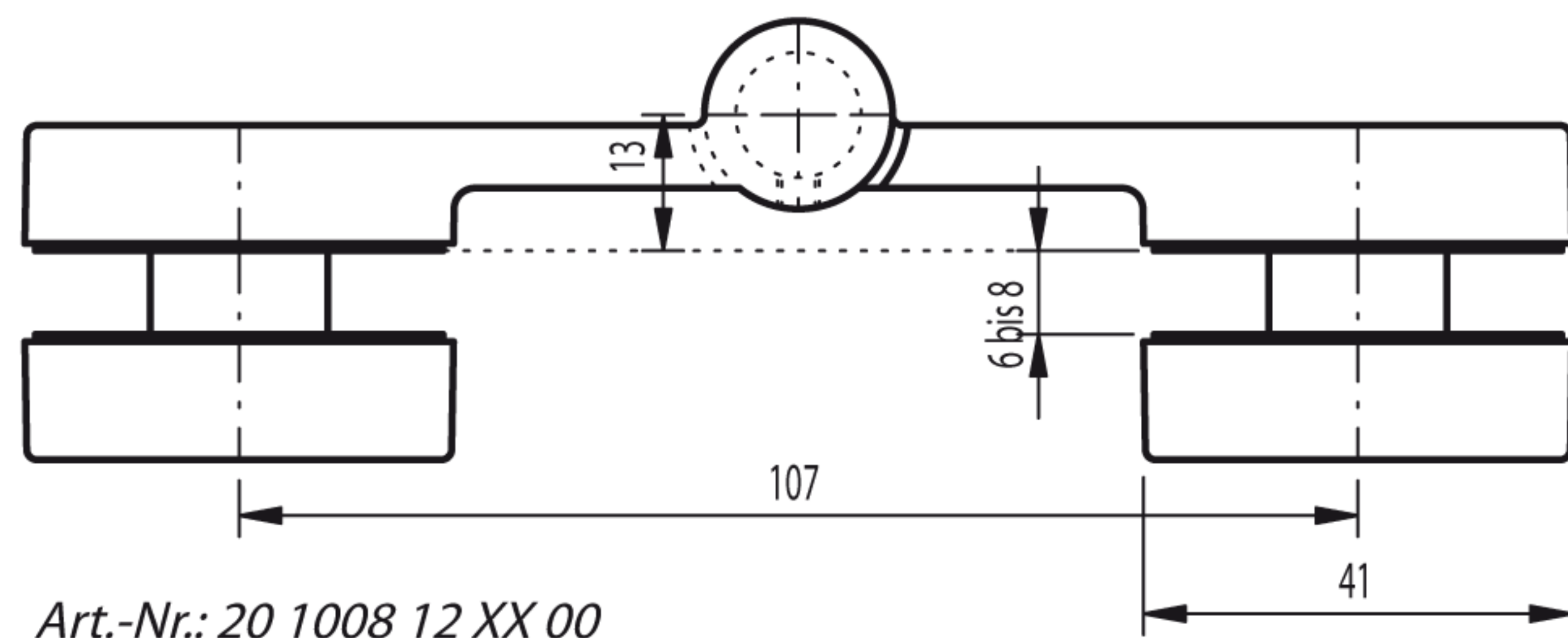
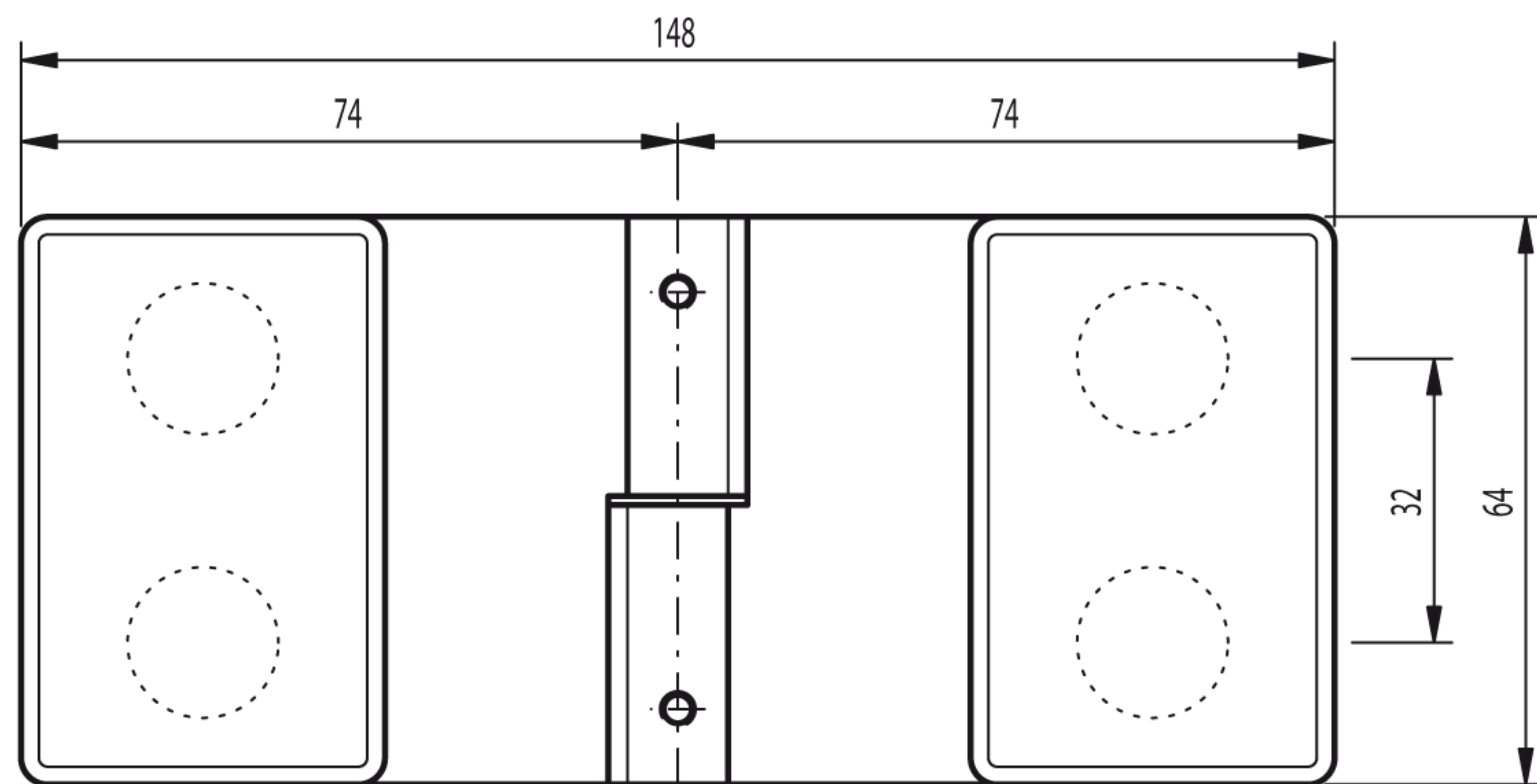

Art.-Nr.: 20 1008 12 XX 00

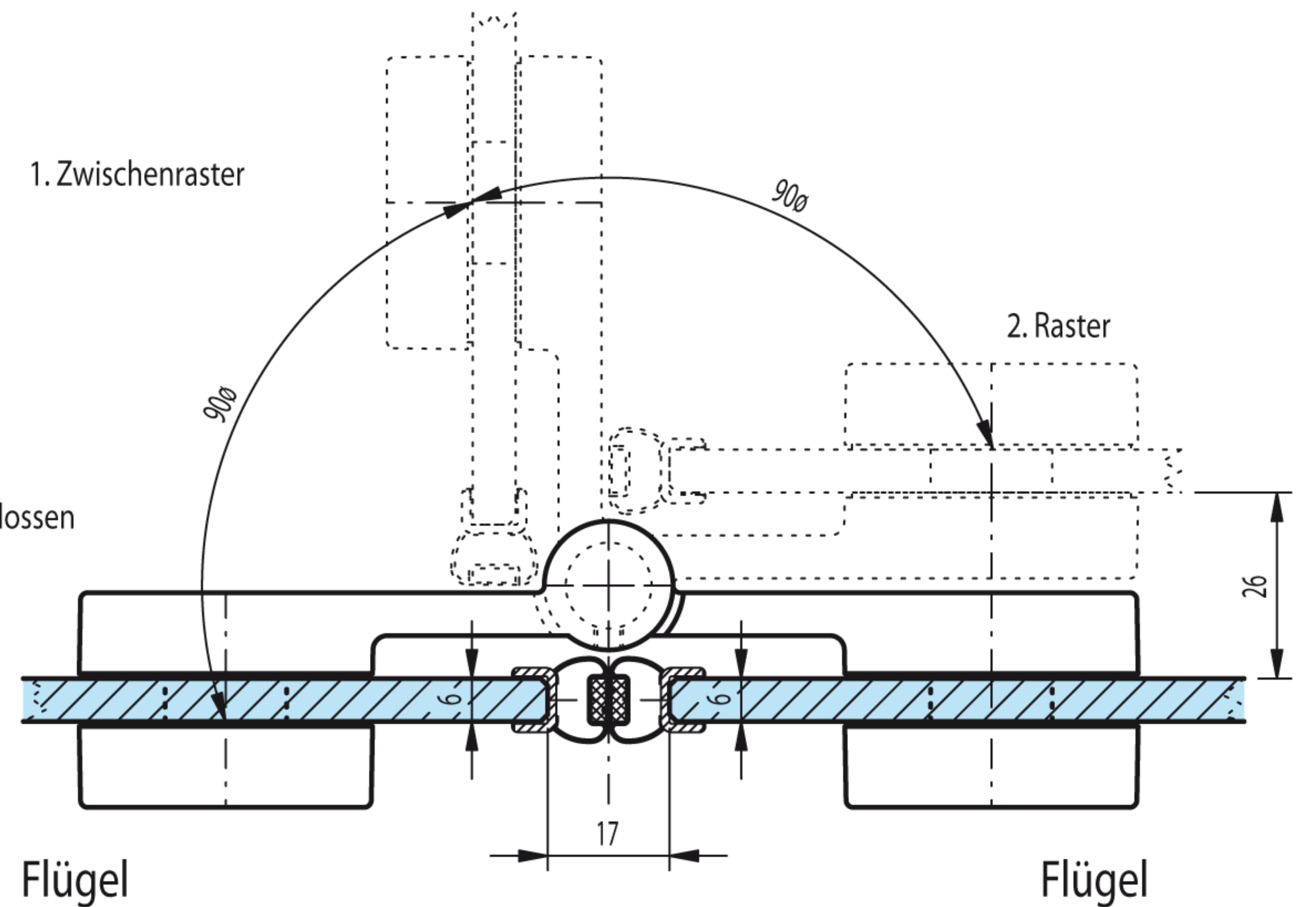

Flügel

Flügel