

EINBAU-Skizze 90° / DIN - links = Art.-Nr.: 20_1007_12_XX_53

Glasbearbeitung bei Verwendung von
Magnetdichtungen Nr.20 1156 11 27 04 und Nr.20 1157 11 27 04

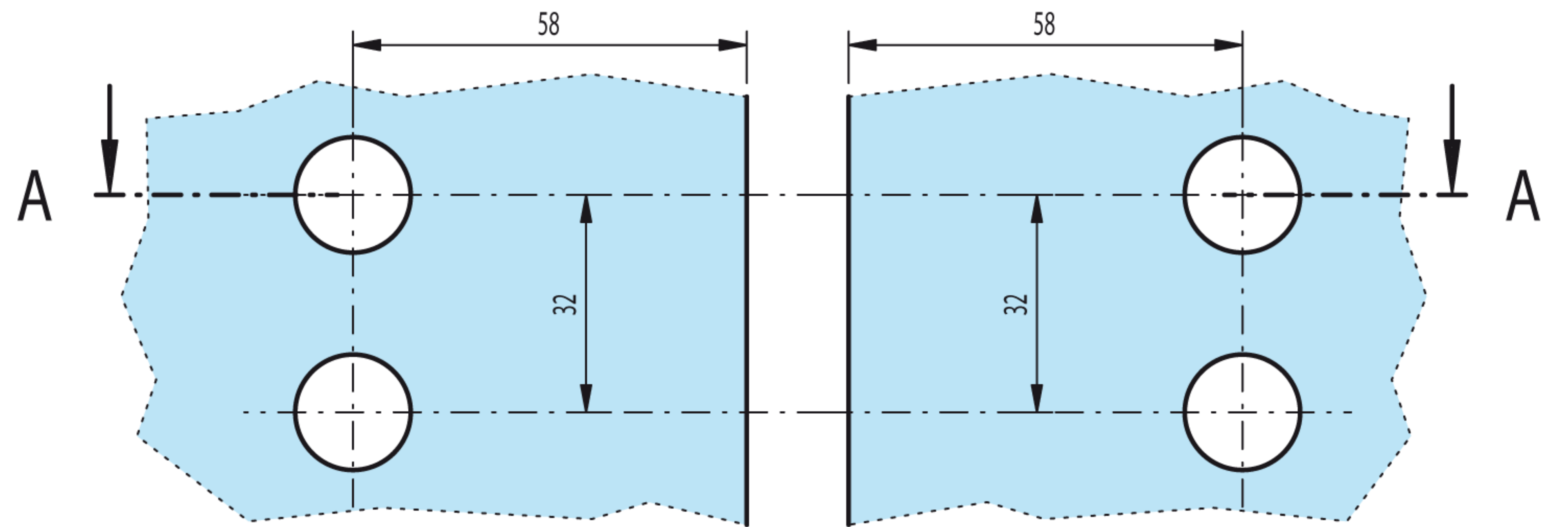

Flügelglas

Flügelglas

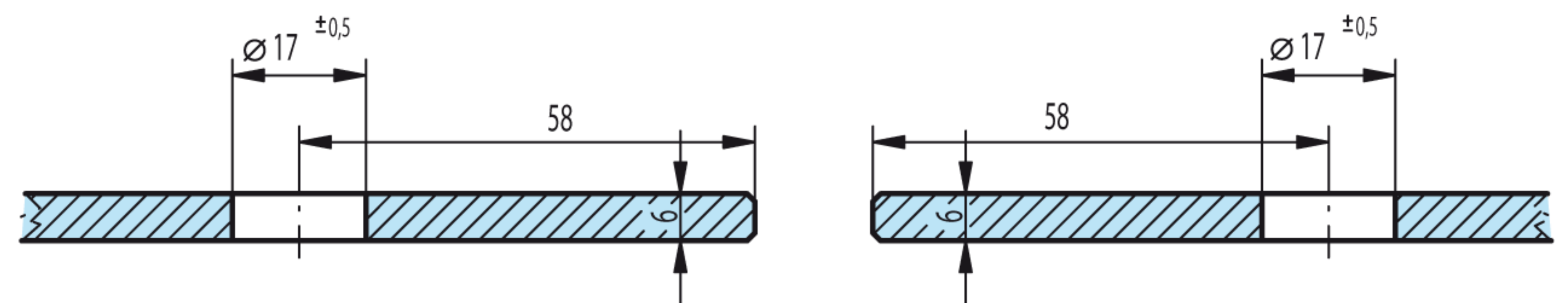

Schnitt: A-A (M1:1)

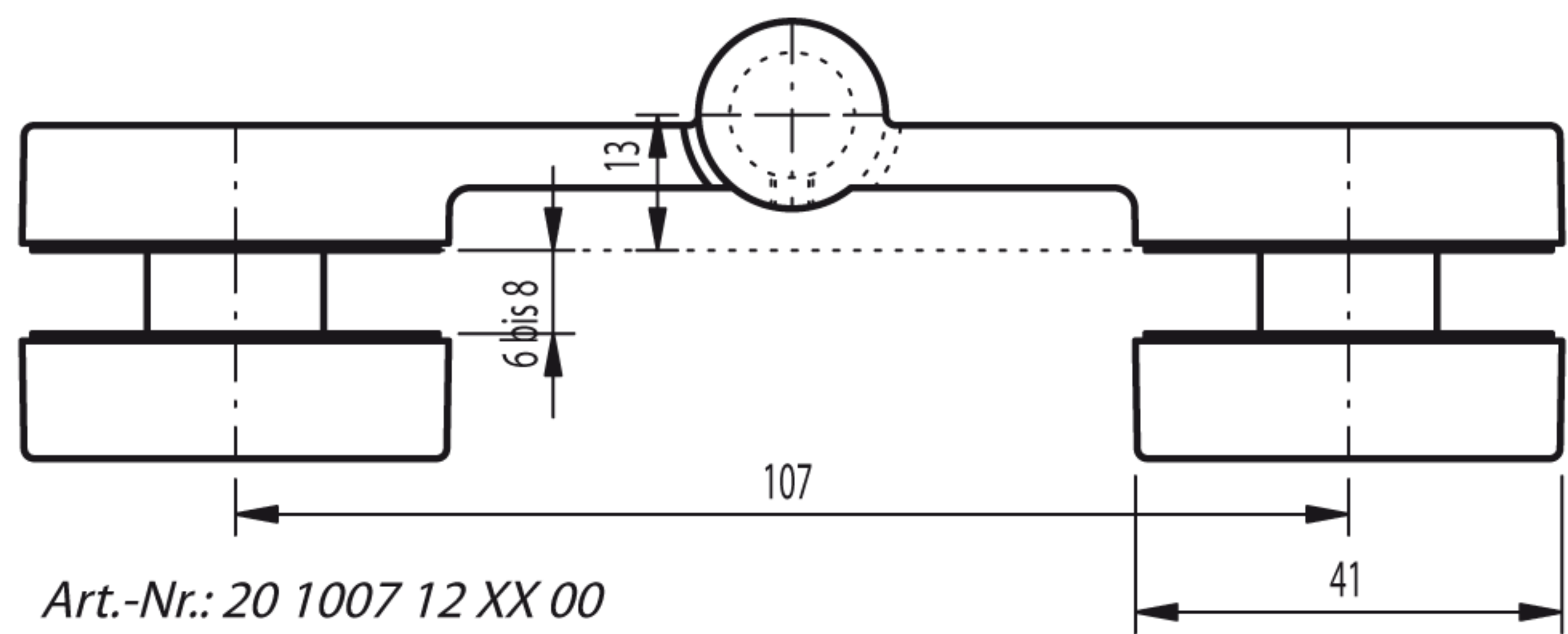
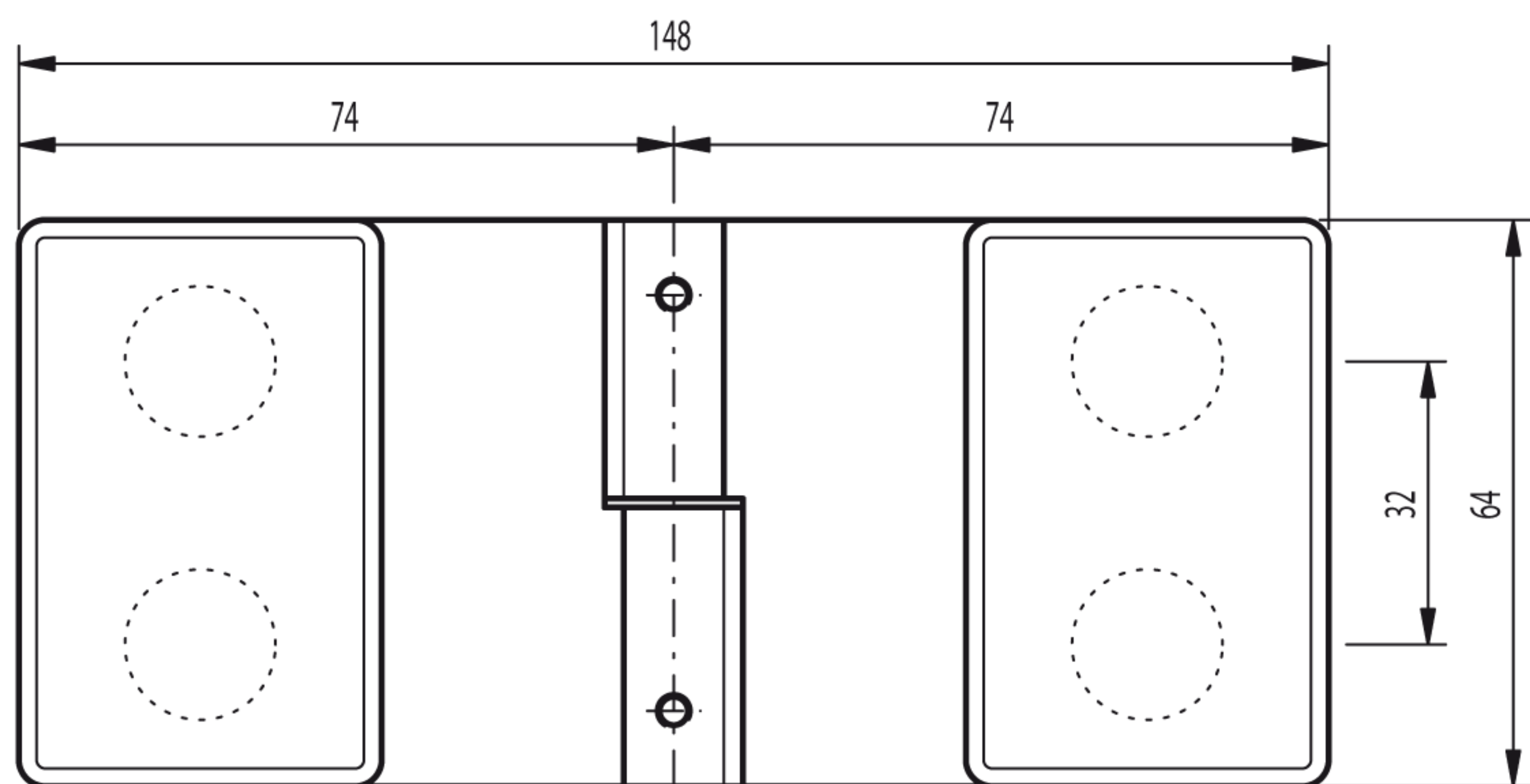

Art.-Nr.: 20 1007 12 XX 00

