

Glasbearbeitung bei Verwendung von
Magnetdichtung Nr. 20 1150 11 27 01

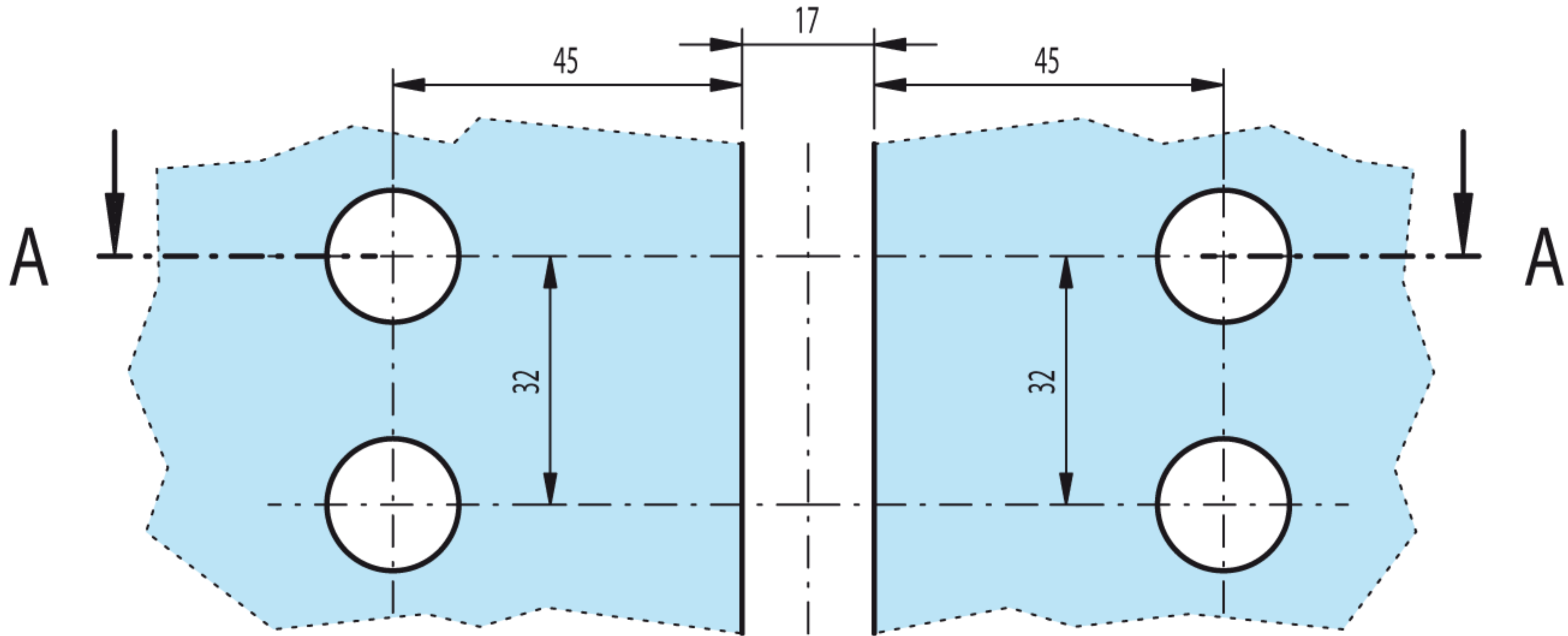

Flügelglas

Flügelglas

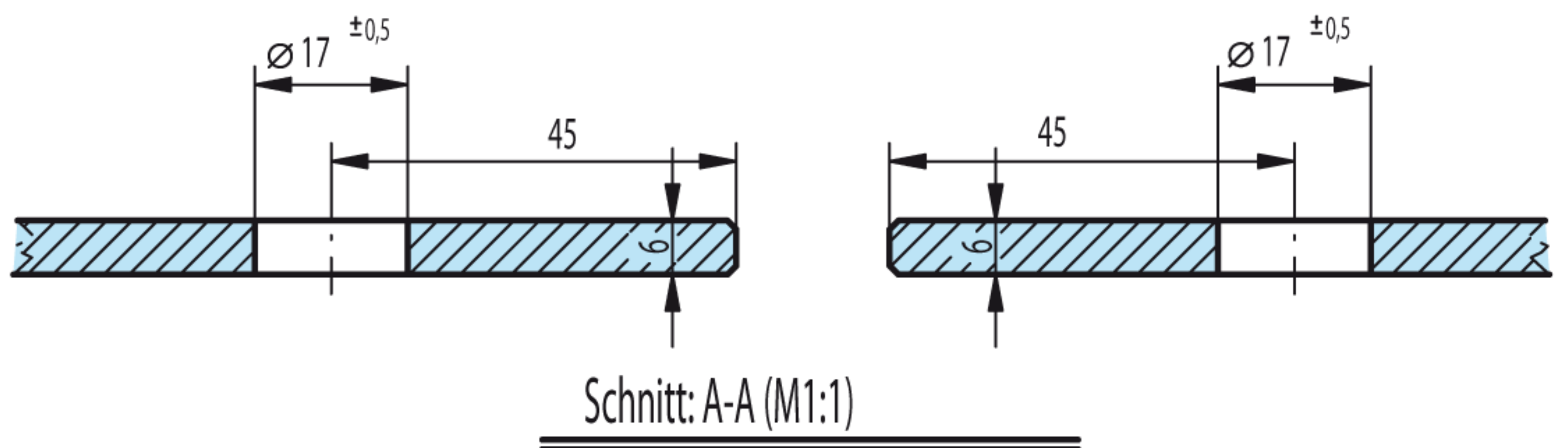

Schnitt: A-A (M1:1)

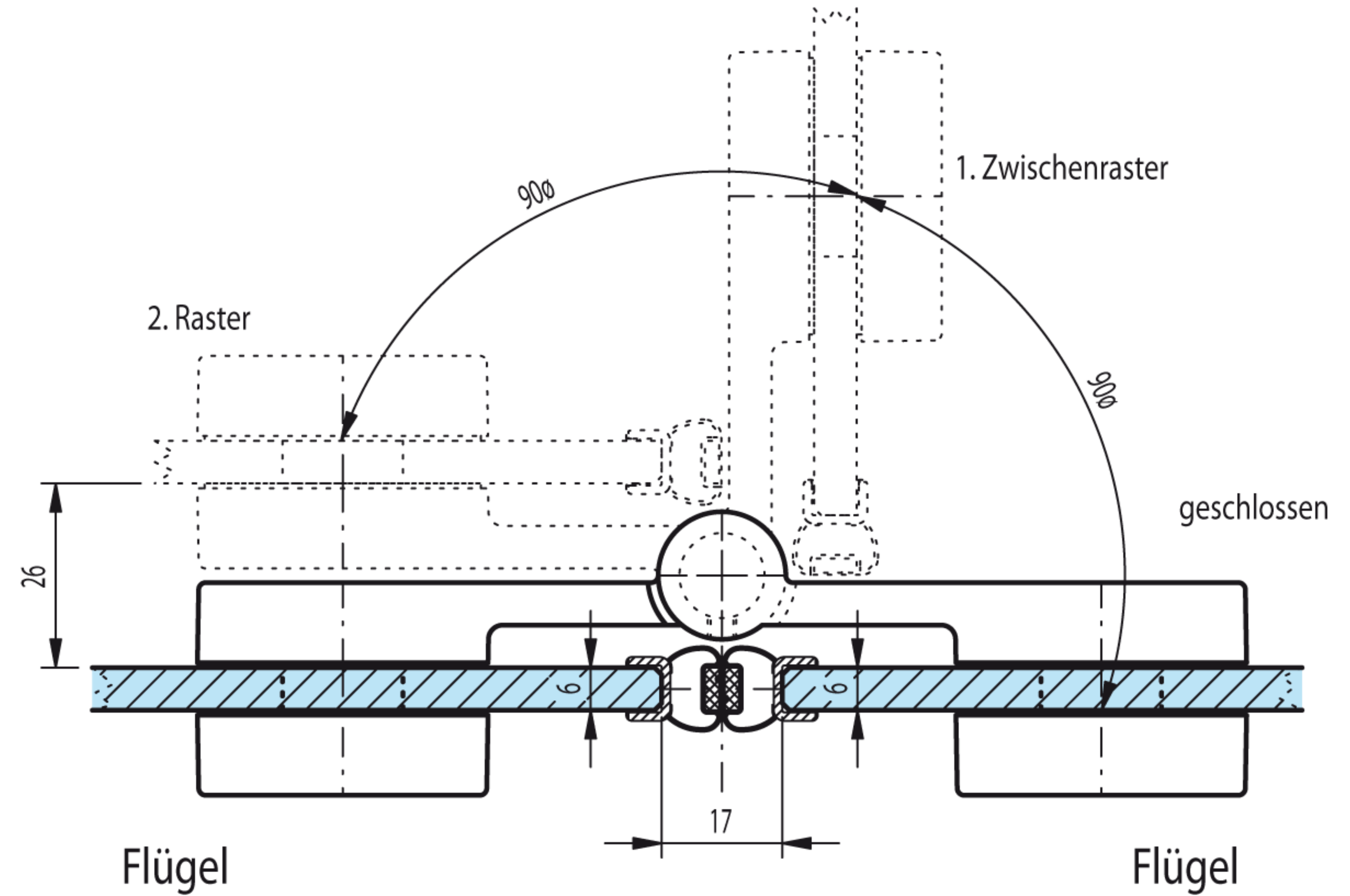
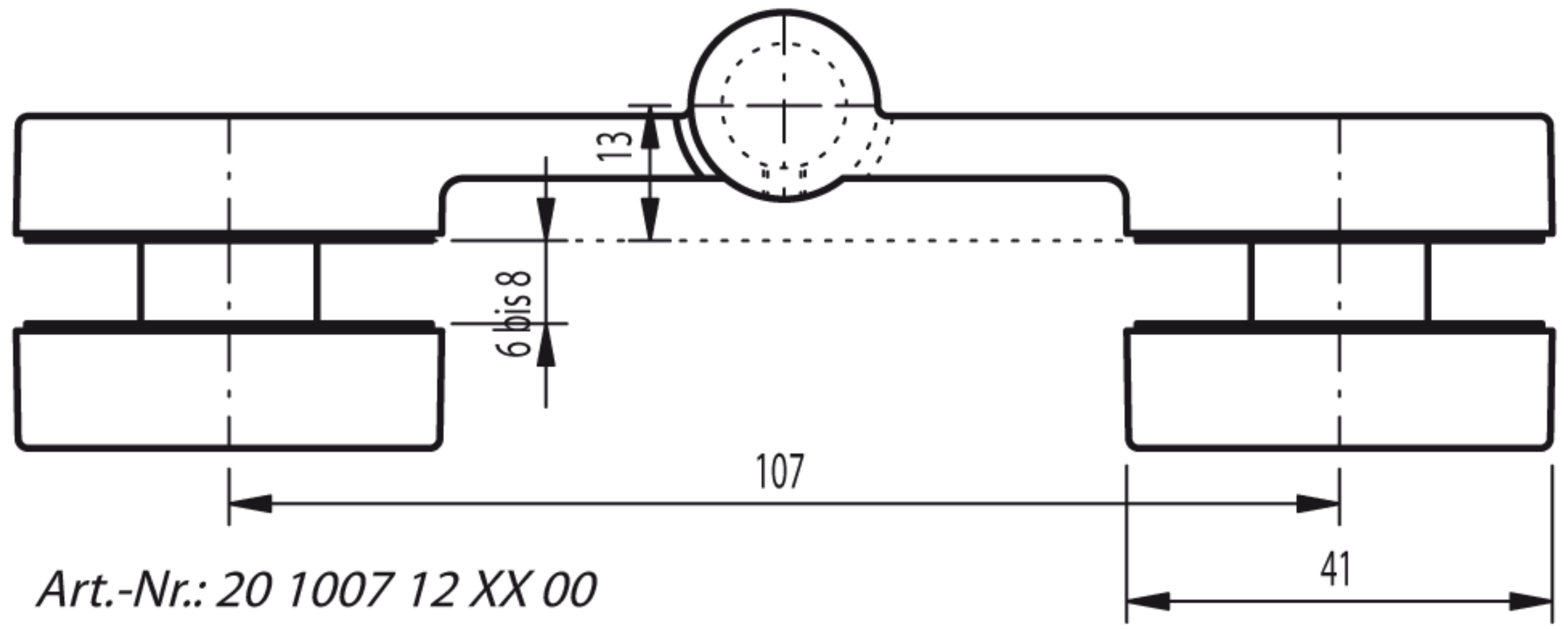
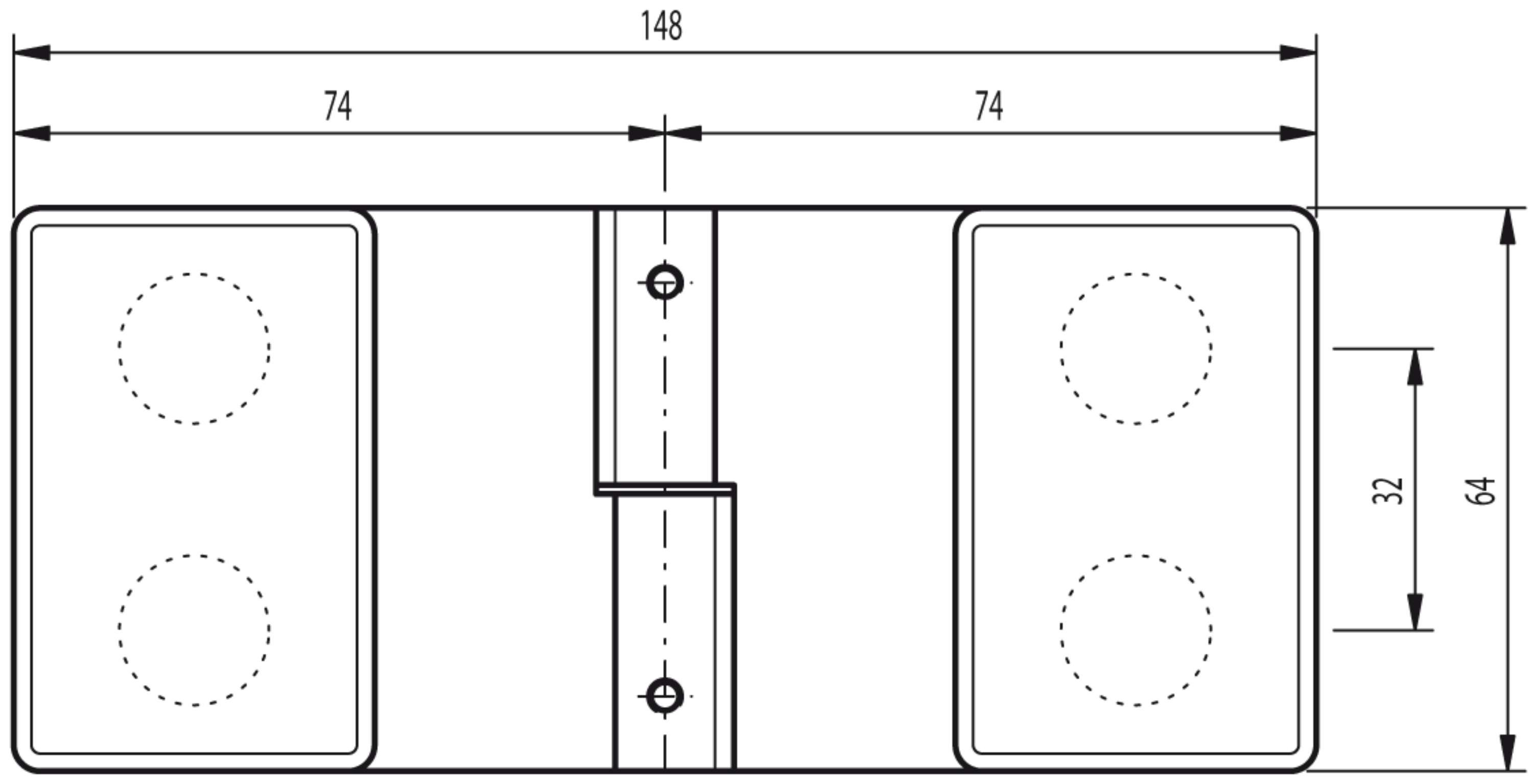

Flügel

Flügel