

EINBAU-Skizze 90° / DIN - rechts = Art.-Nr.:20_1006_12_XX_03

Glasbearbeitung bei Verwendung von

Magnetdichtungen Nr.20 1156 11 27 04 und Nr.20 1157 11 27 04

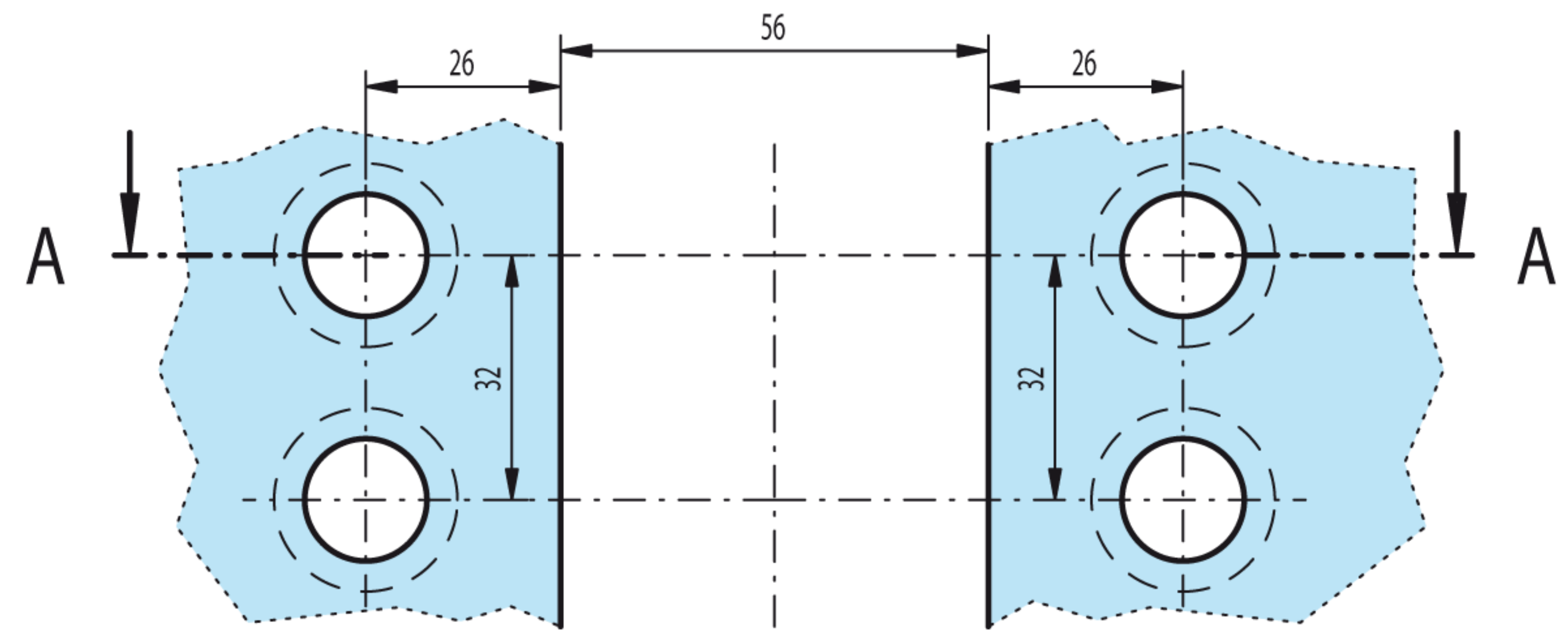

Flügelglas

(Senkung = Innenseite)

Flügelglas

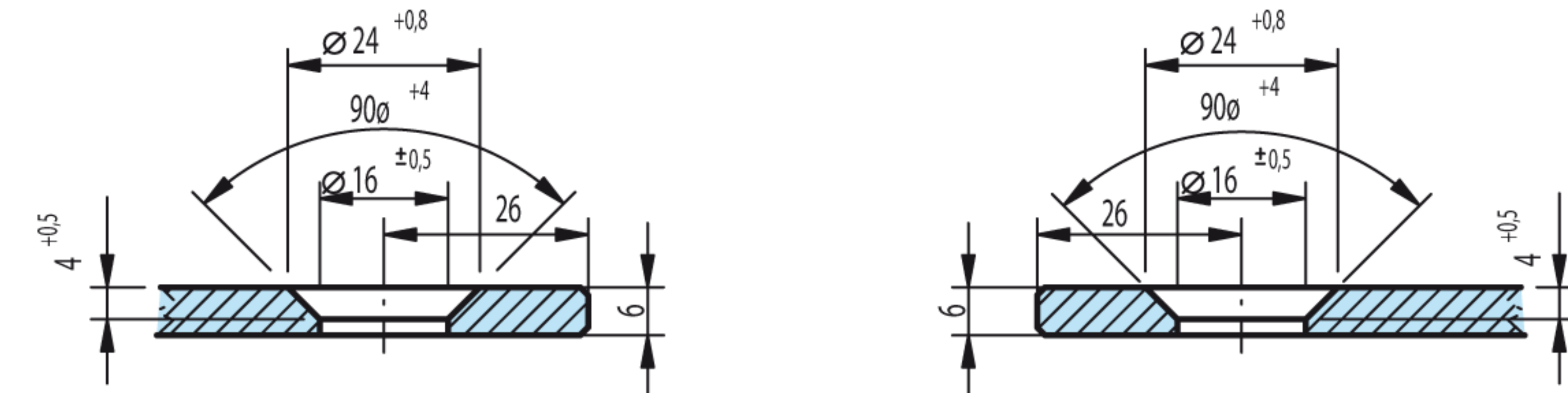

Schnitt: A-A (M1:1)

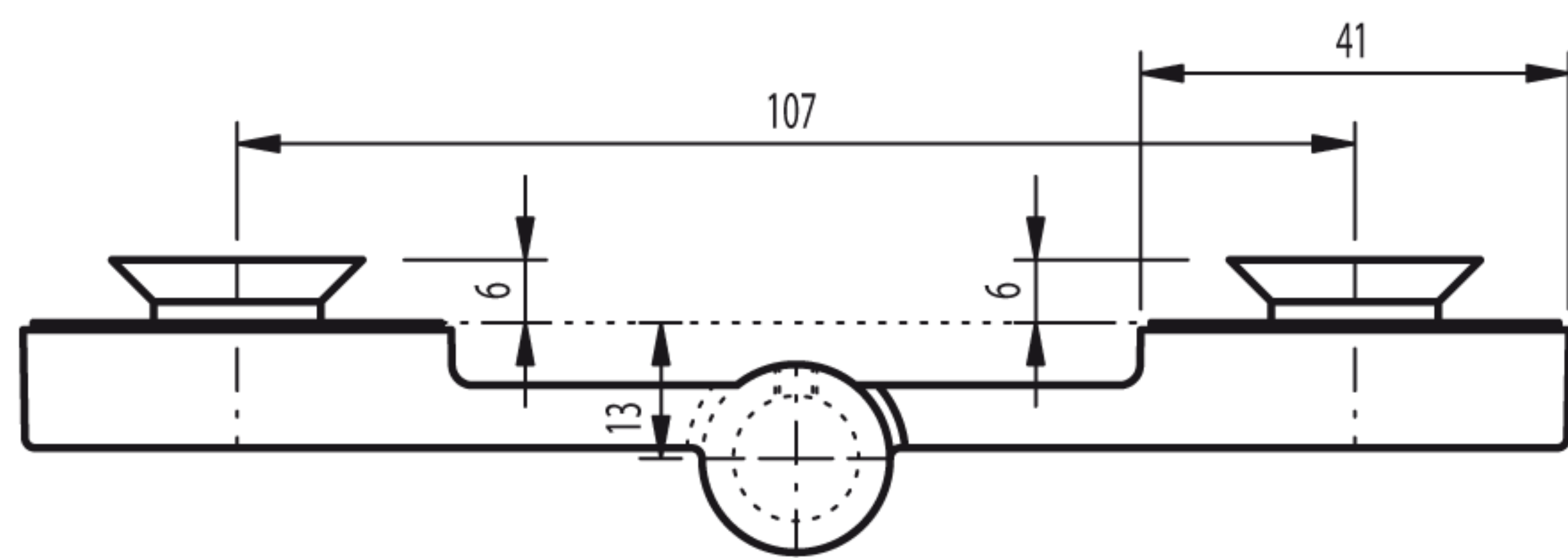
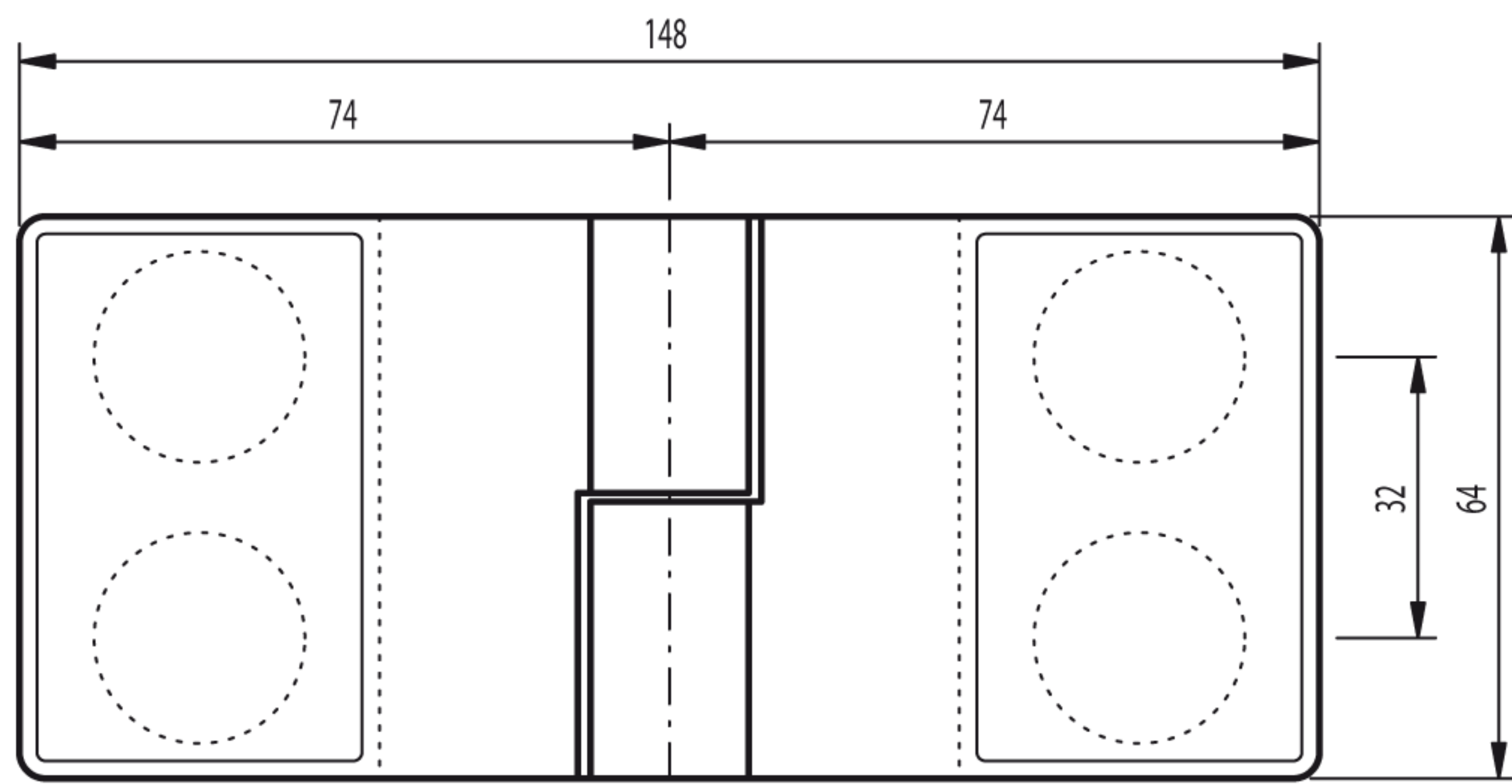

Art.-Nr.: 20 1006 12 XX 00

