

# EINBAU-Skizze 180° / DIN - rechts = Art.-Nr.:20\_1006\_12\_XX\_01

Glasbearbeitung bei Verwendung von  
Magnetdichtung Nr.20 1150 11 27 01

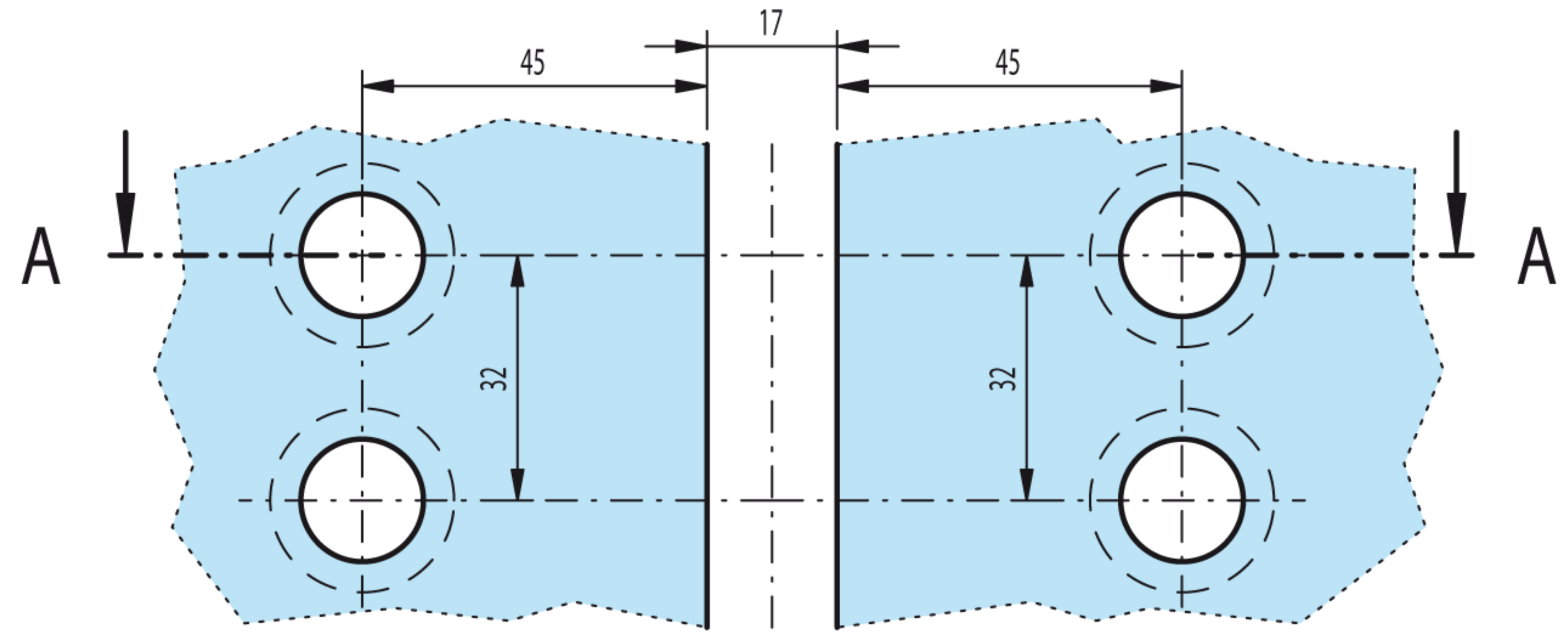

Flügelglas (Senkung = Innenseite) Flügelglas

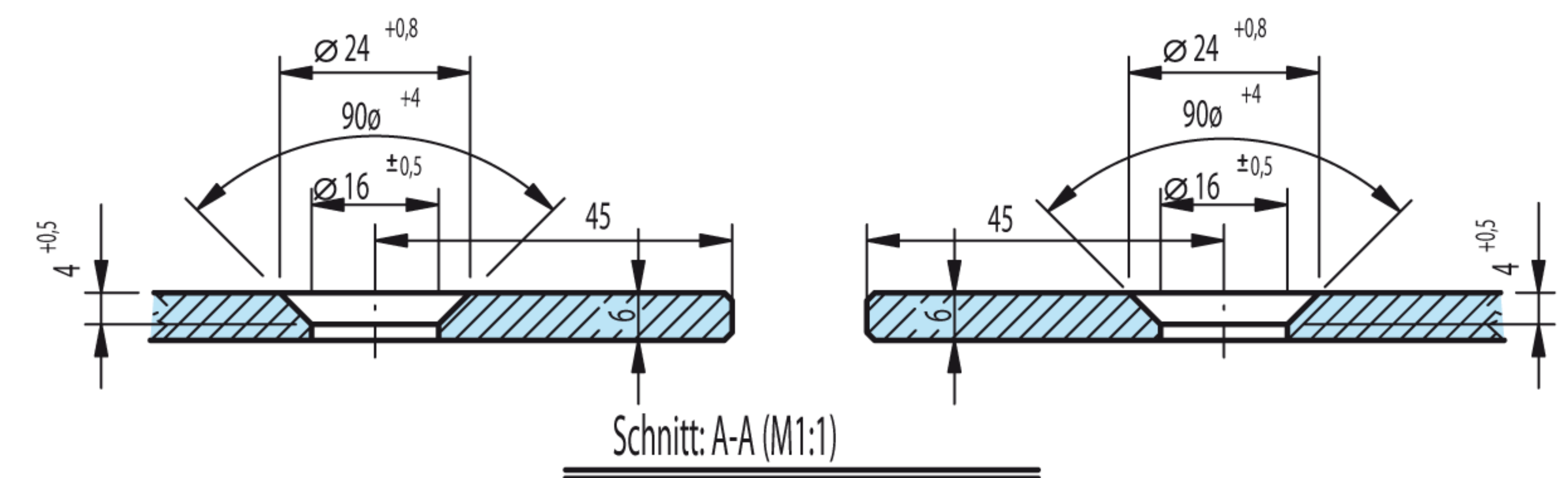

Schnitt: A-A (M1:1)

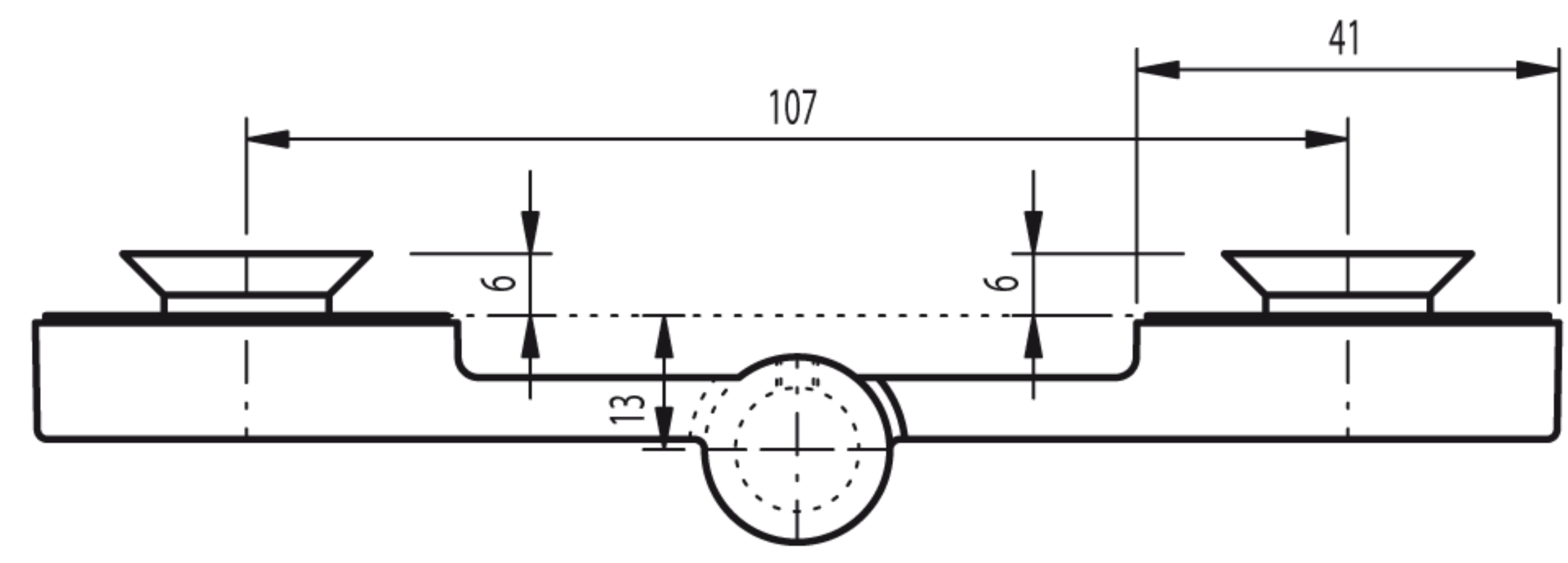
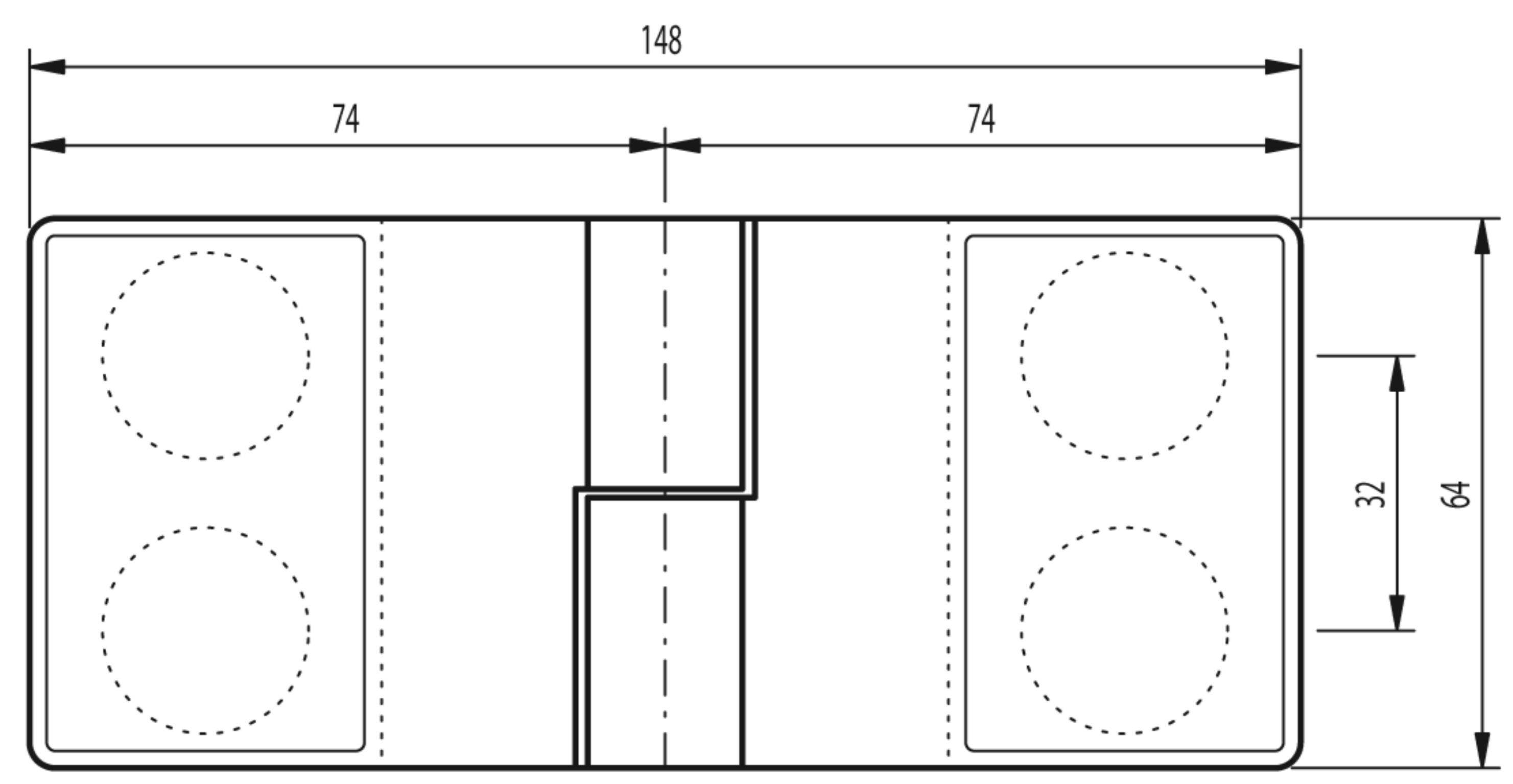
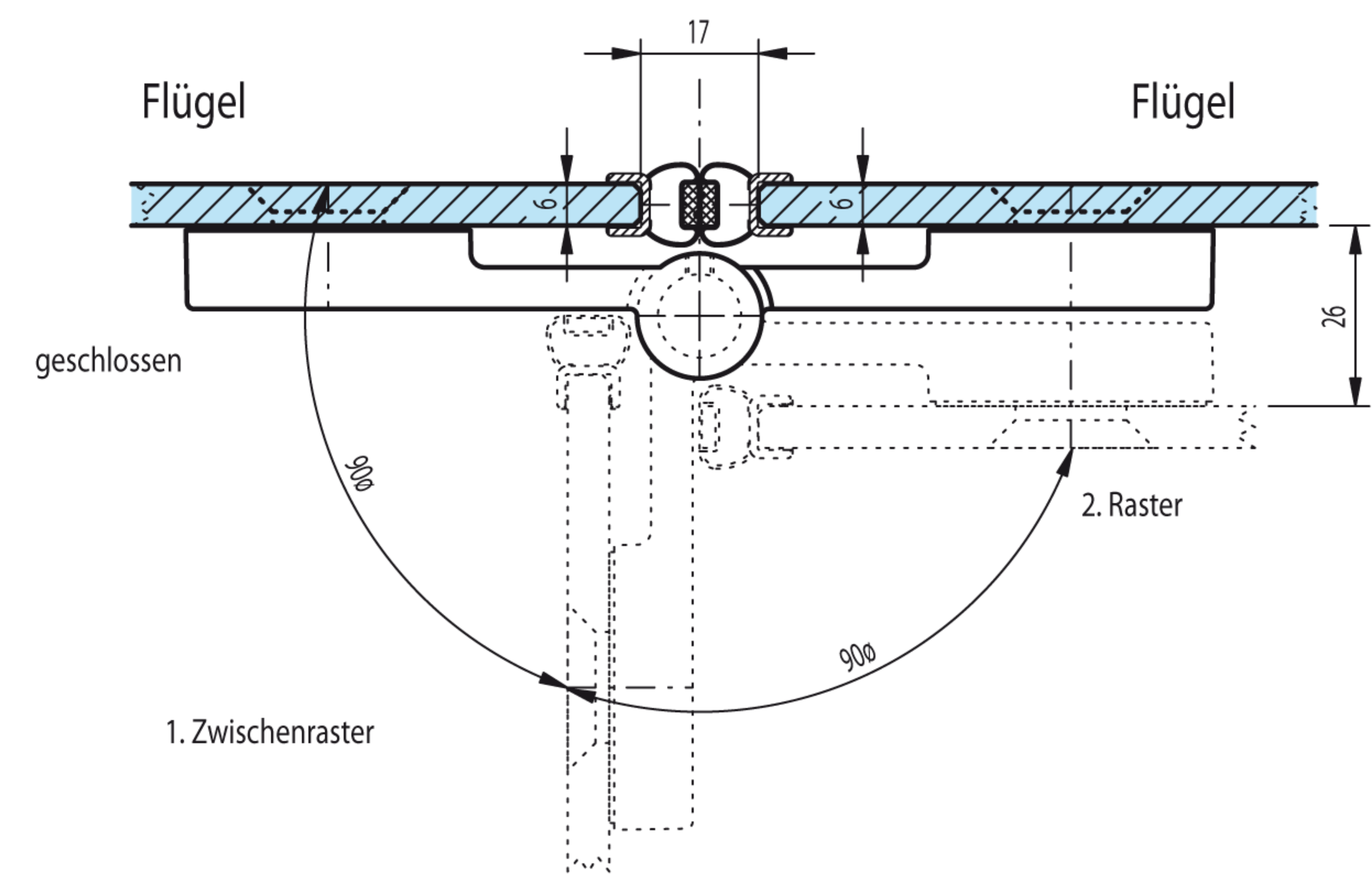

Art.-Nr.: 20 1006 12 XX 00