

# EINBAU-Skizze 180° / DIN - links = Art.-Nr.:20\_1005\_12\_XX\_01

Glasbearbeitung bei Verwendung von  
Magnetdichtung Nr.20 1150 11 27 01

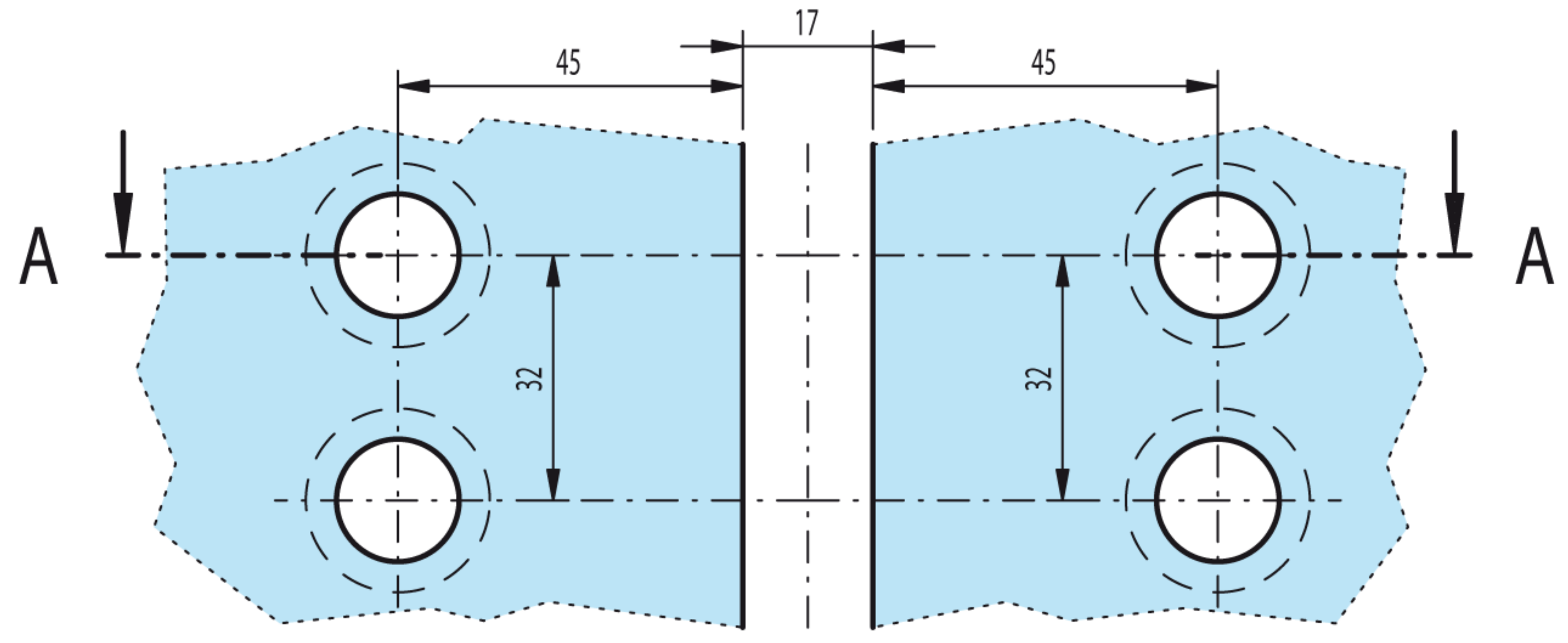

Flügelglas (Senkung = Innenseite) Flügelglas

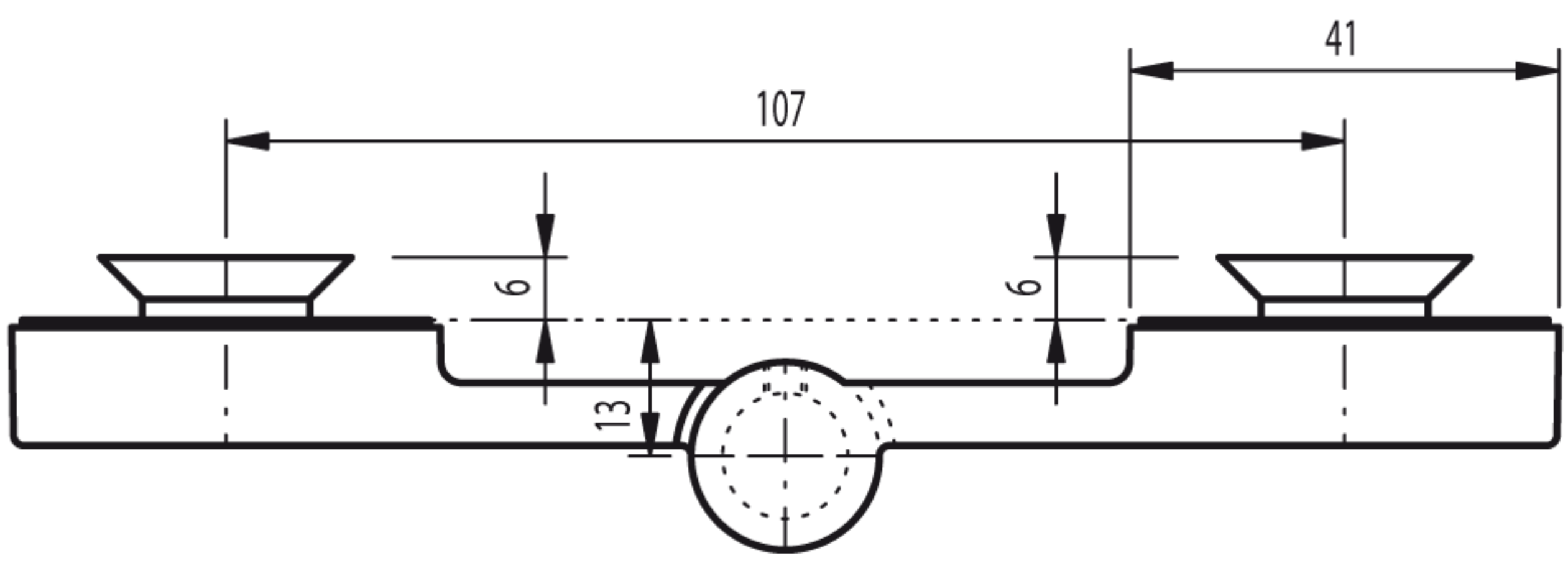
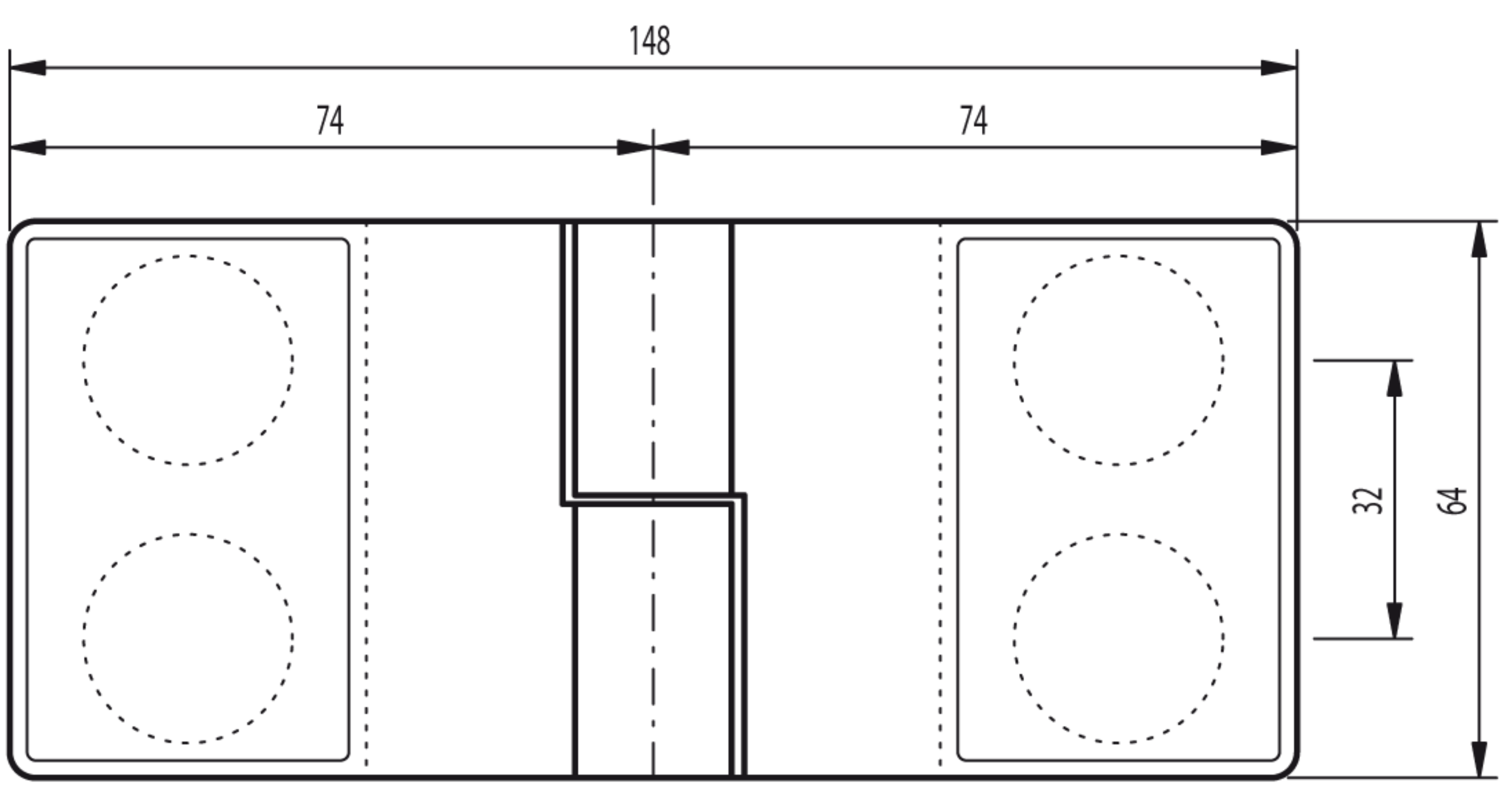
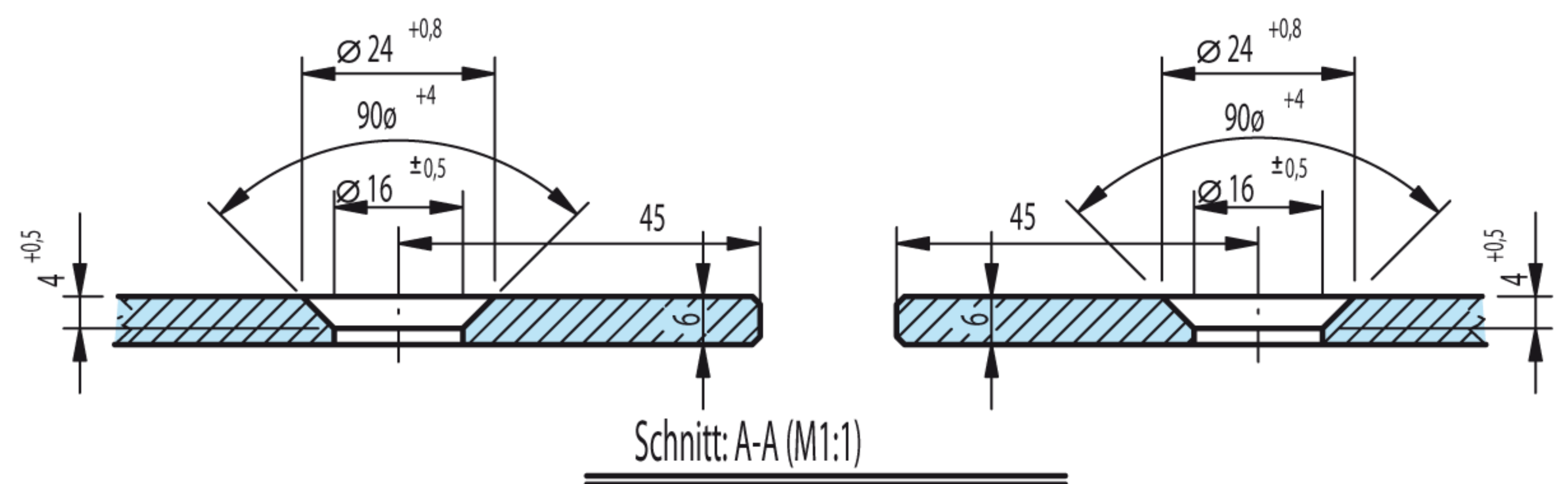

Art.-Nr.: 20 1005 12 XX 00

