

EINBAU-Skizze 180° / DIN - links = Art.-Nr.:20_1003_12_XX_01

Glasbearbeitung bei Verwendung von
Magnetdichtung Nr. 20 1168 11 27 01 / 20 1169 11 27 01

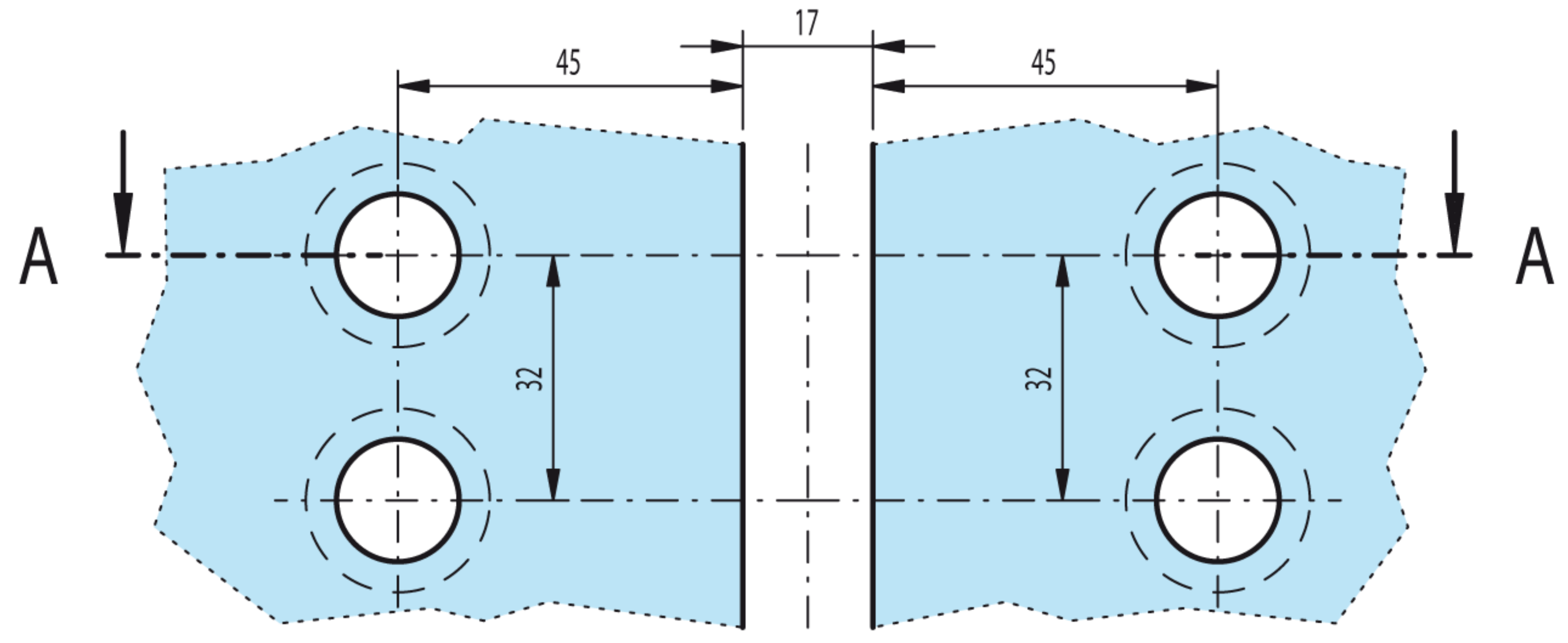

Flügelglas (Senkung = Innenseite) Flügelglas

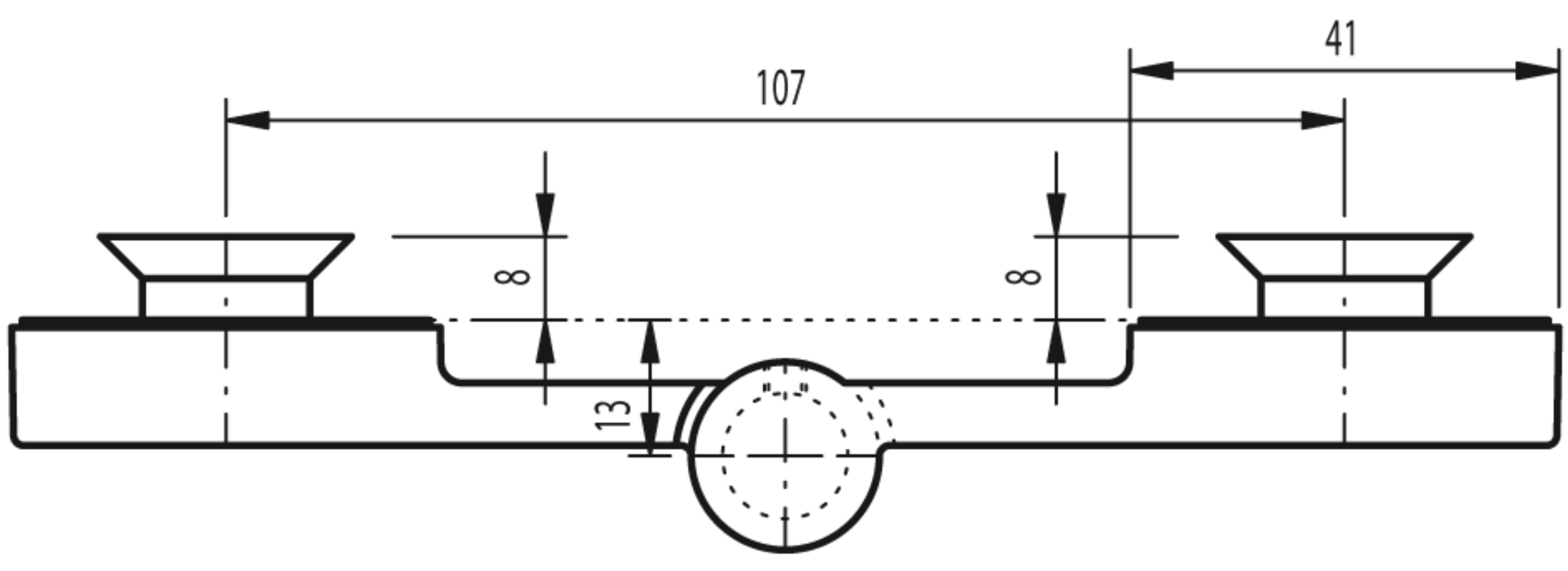
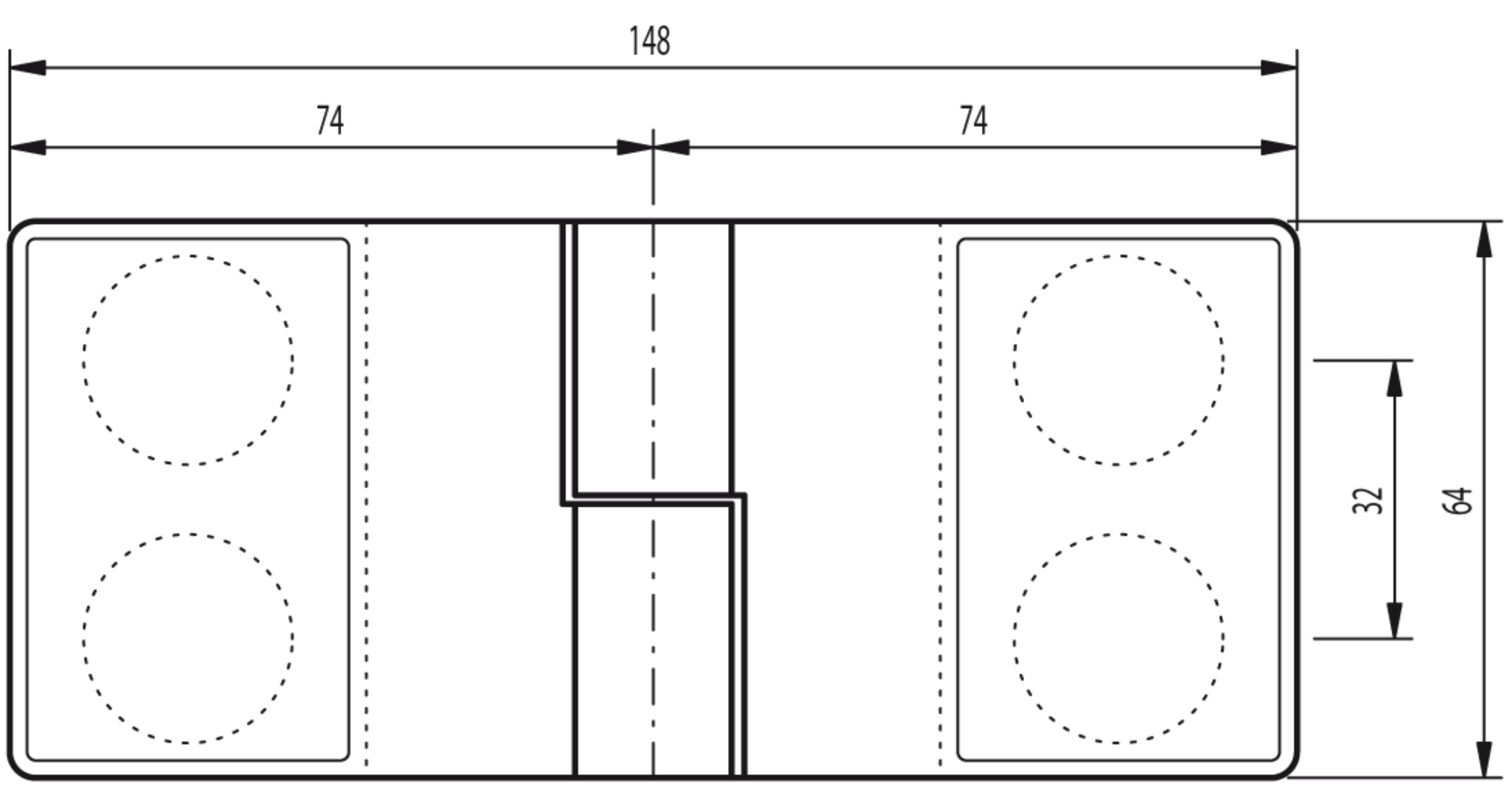
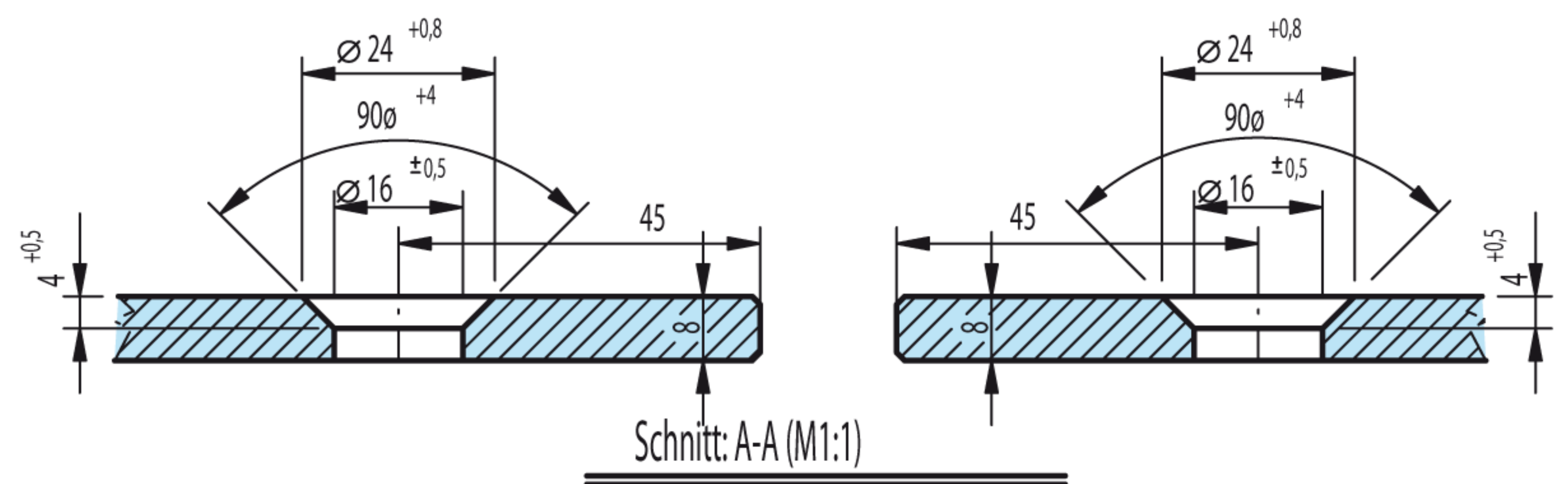

Art.-Nr.: 20 1003 12 XX 00

