

Glasbearbeitung bei Verwendung von  
Balgdichtung Nr. 20 1158 11 27 00

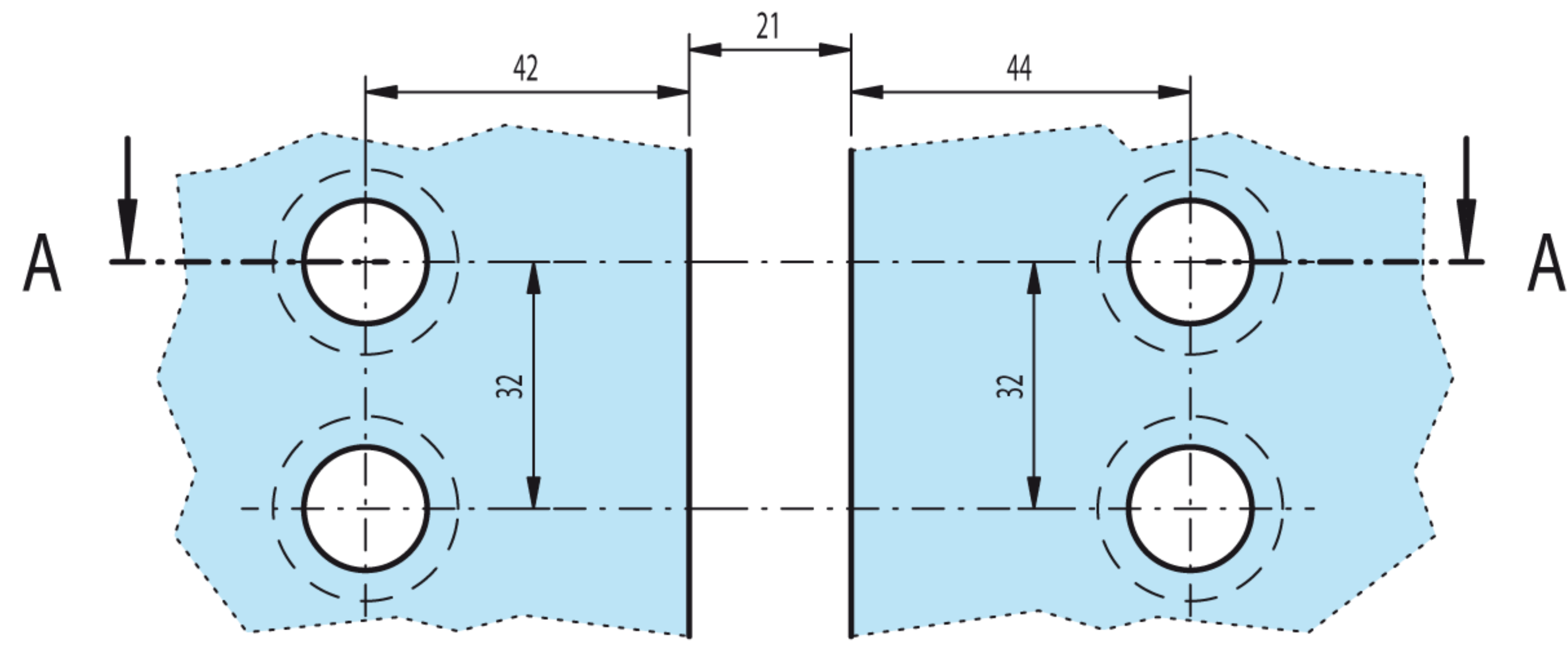

Flügelglas (Senkung = Innenseite) Festteilglas

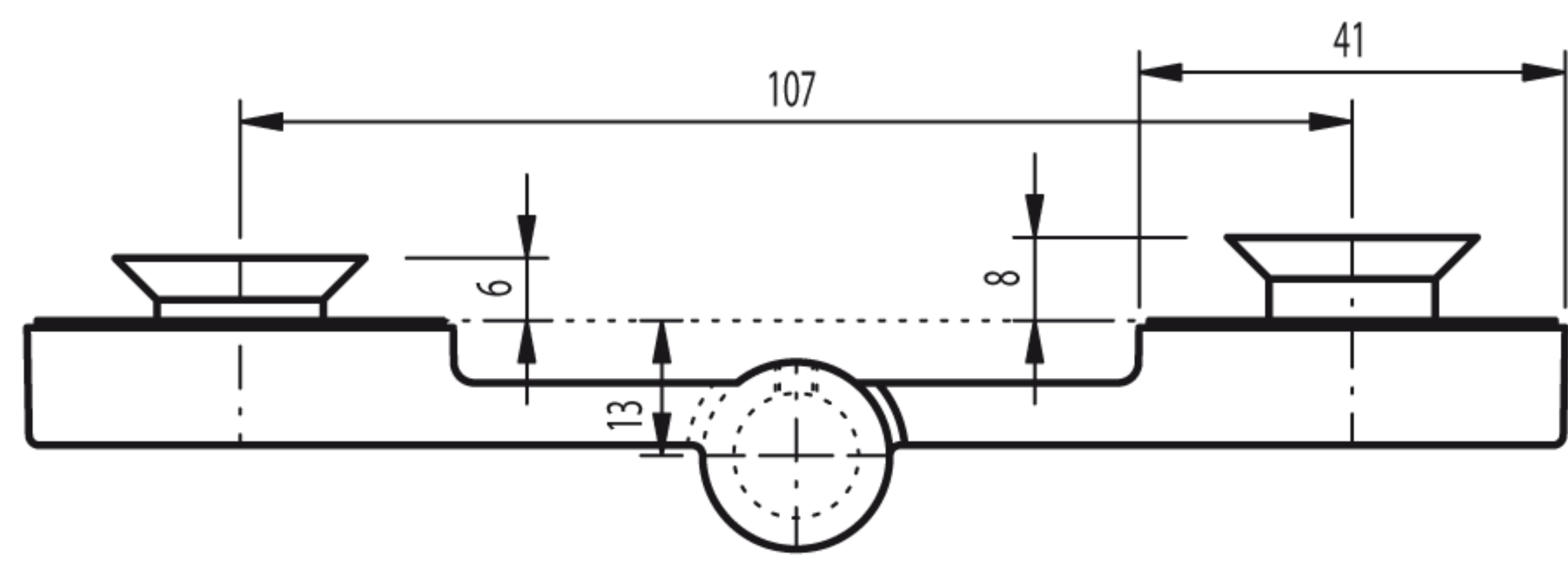
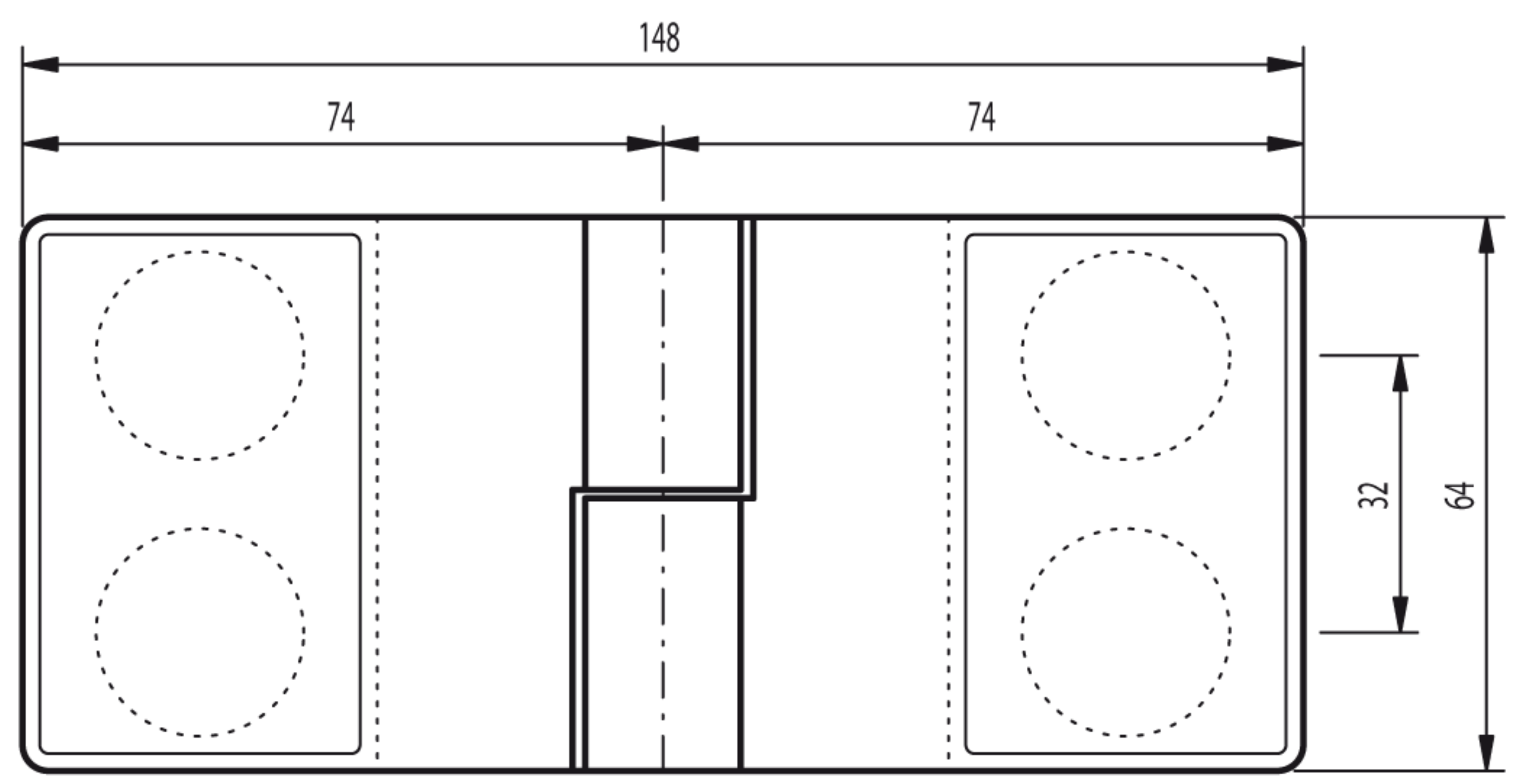
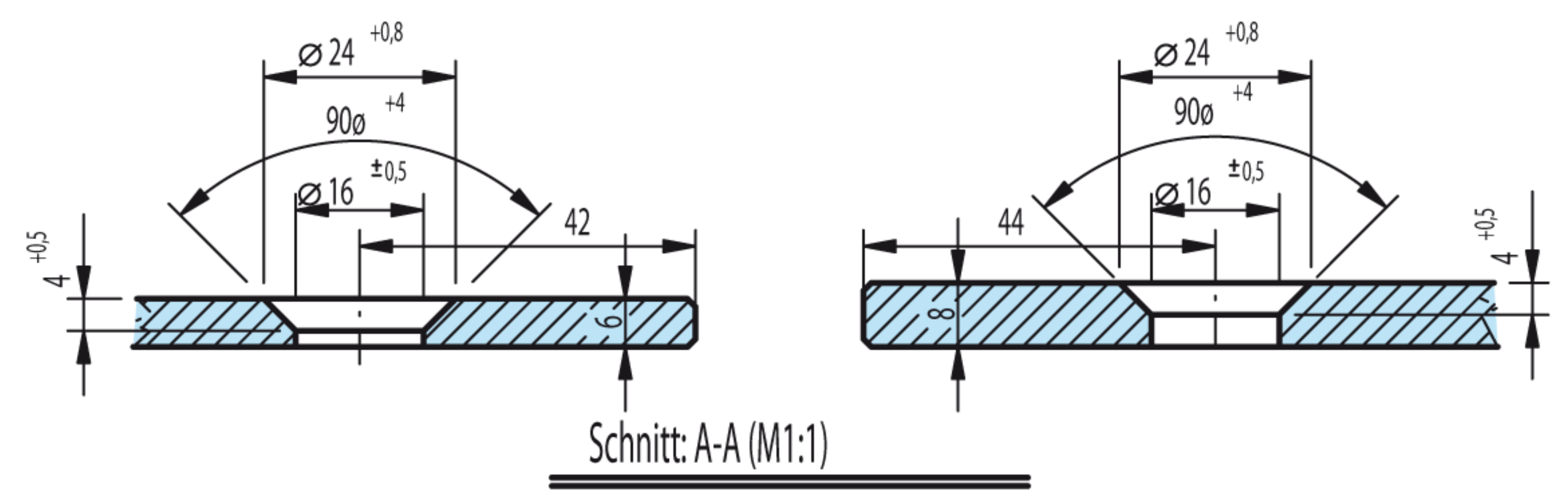

Art.-Nr.: 20 1002 12 XX 00

