

EINBAU-Skizze 90° / DIN - links = Art.-Nr.:20_1001_12_XX_03

Glasbearbeitung bei Verwendung von
Balgdichtung Nr. 20 1160 11 27 00

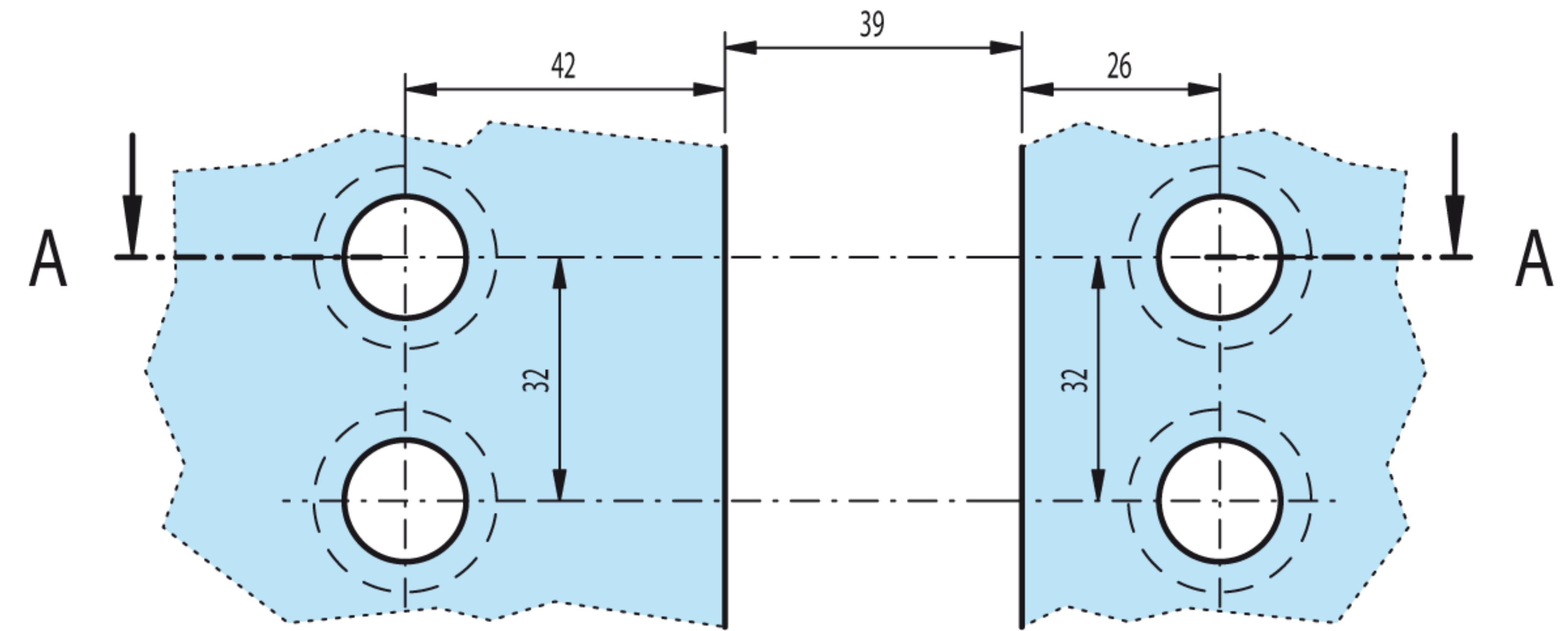

Festteilglas

(Senkung = Innenseite)

Flügelglas

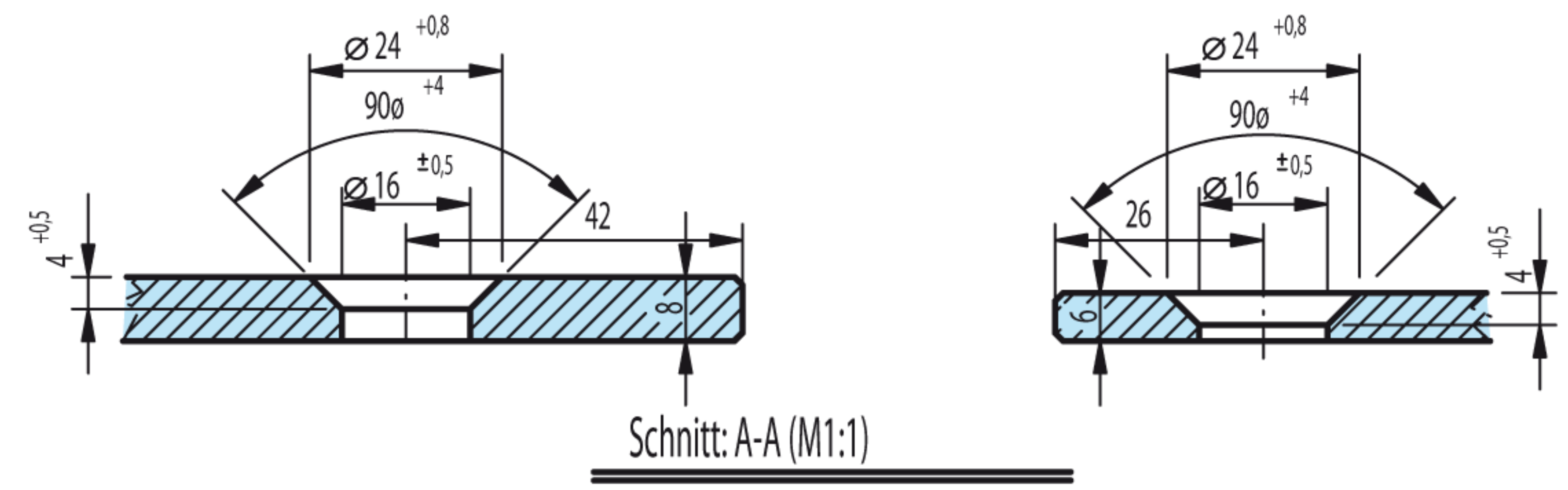

Schnitt: A-A (M1:1)

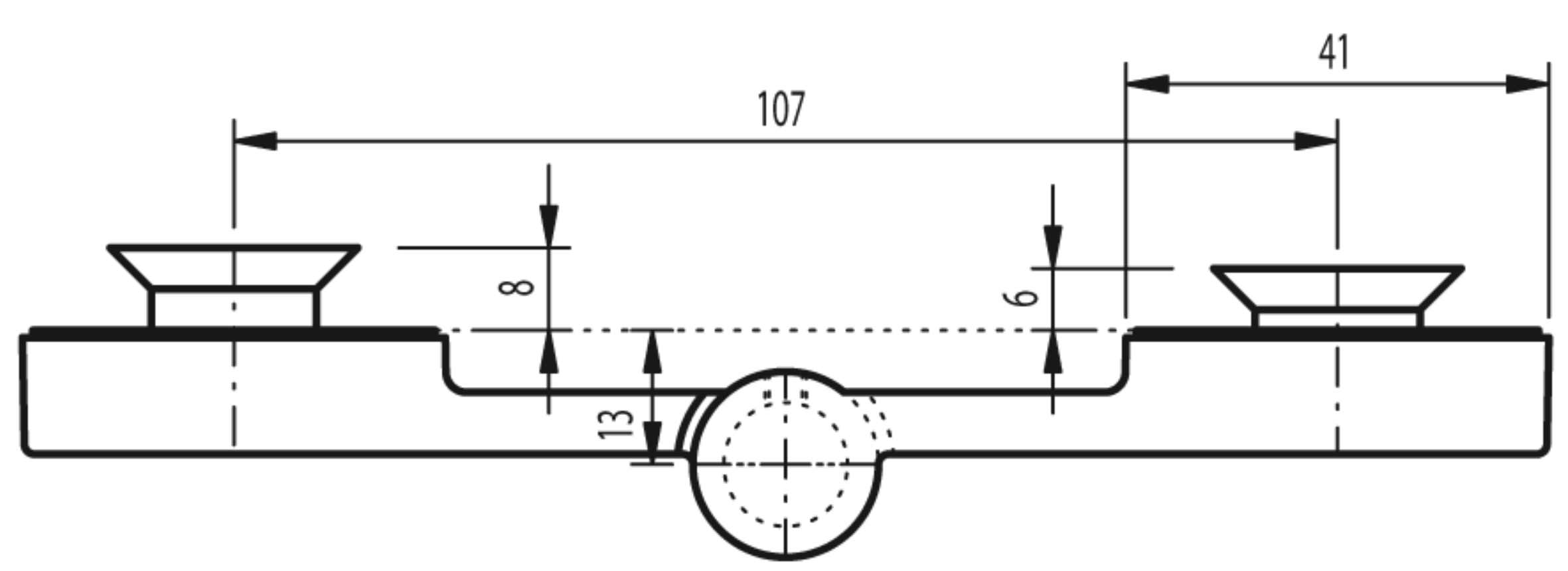
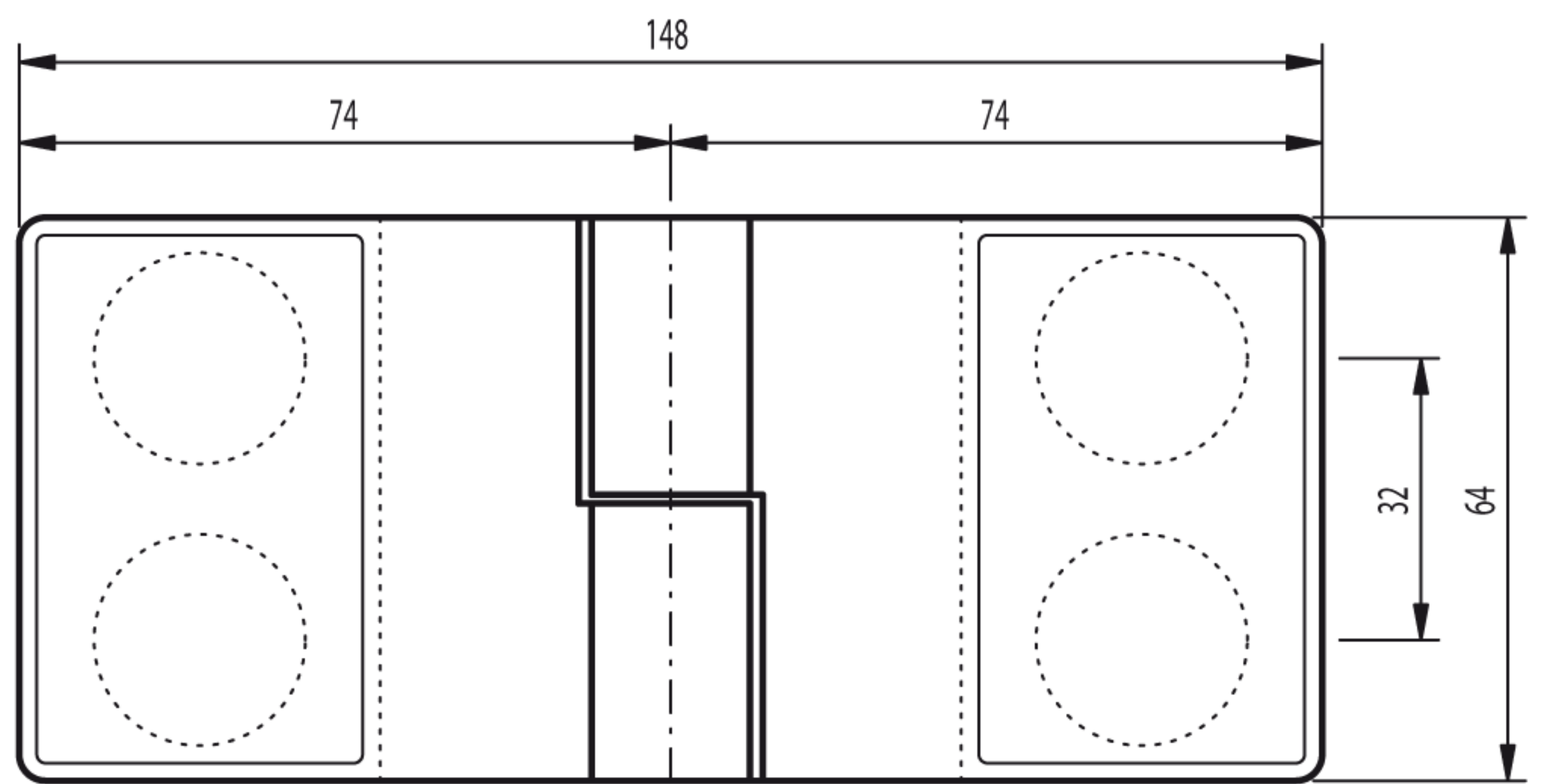
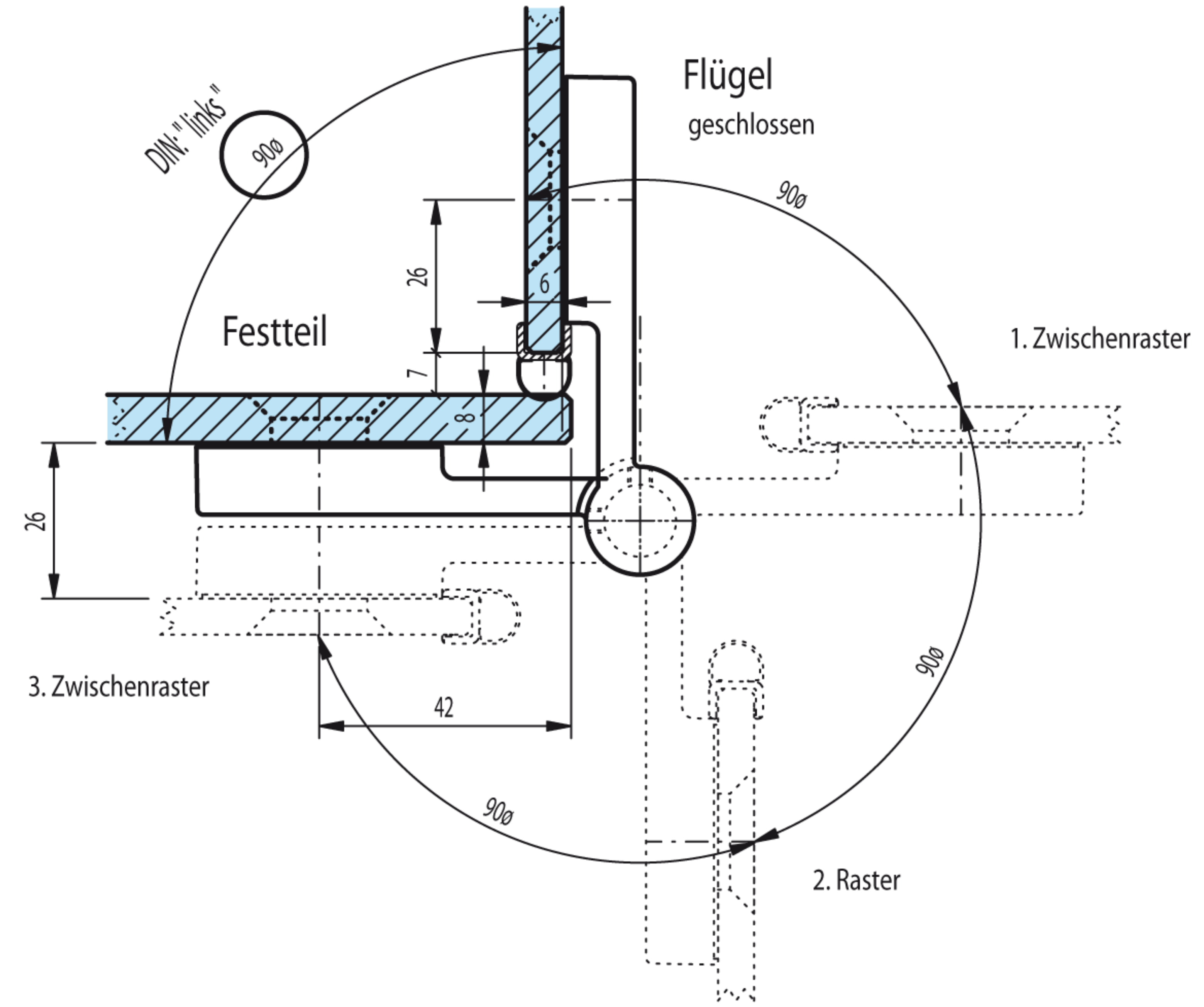

Art.-Nr.: 20 1001 12 XX 00