

EINBAU-Skizze 135ø / DIN - links = Art.-Nr.:20_1001_12_XX_02

Glasbearbeitung bei Verwendung von
Balgdichtung Nr. 20 1158 11 27 00

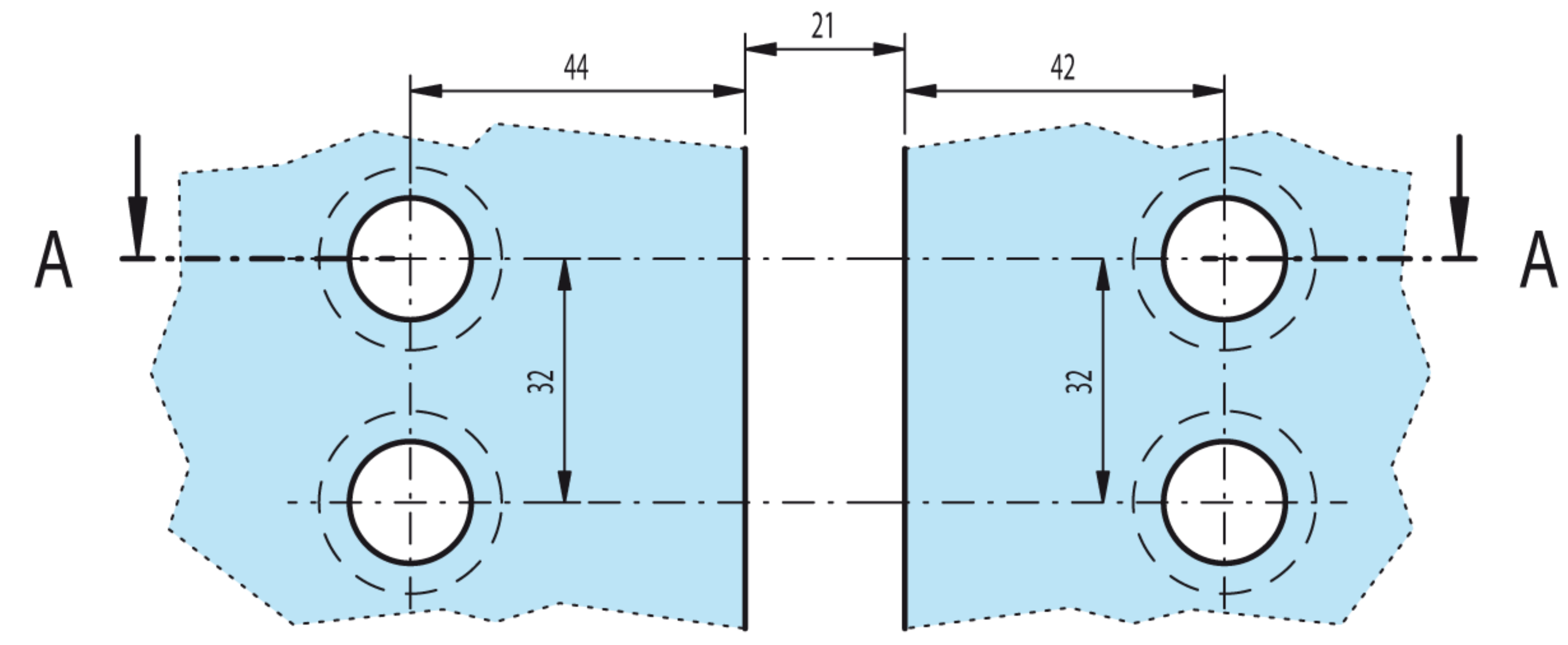

Festteilglas (Senkung = Innenseite) Flügelglas

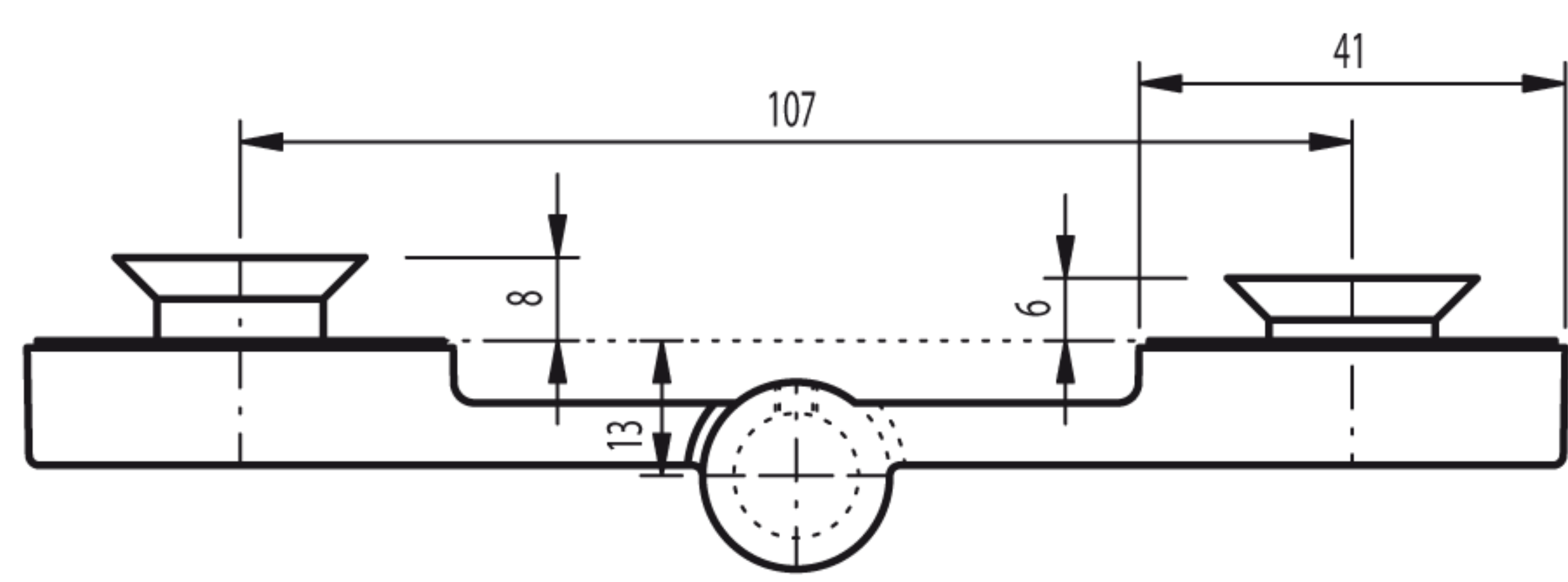
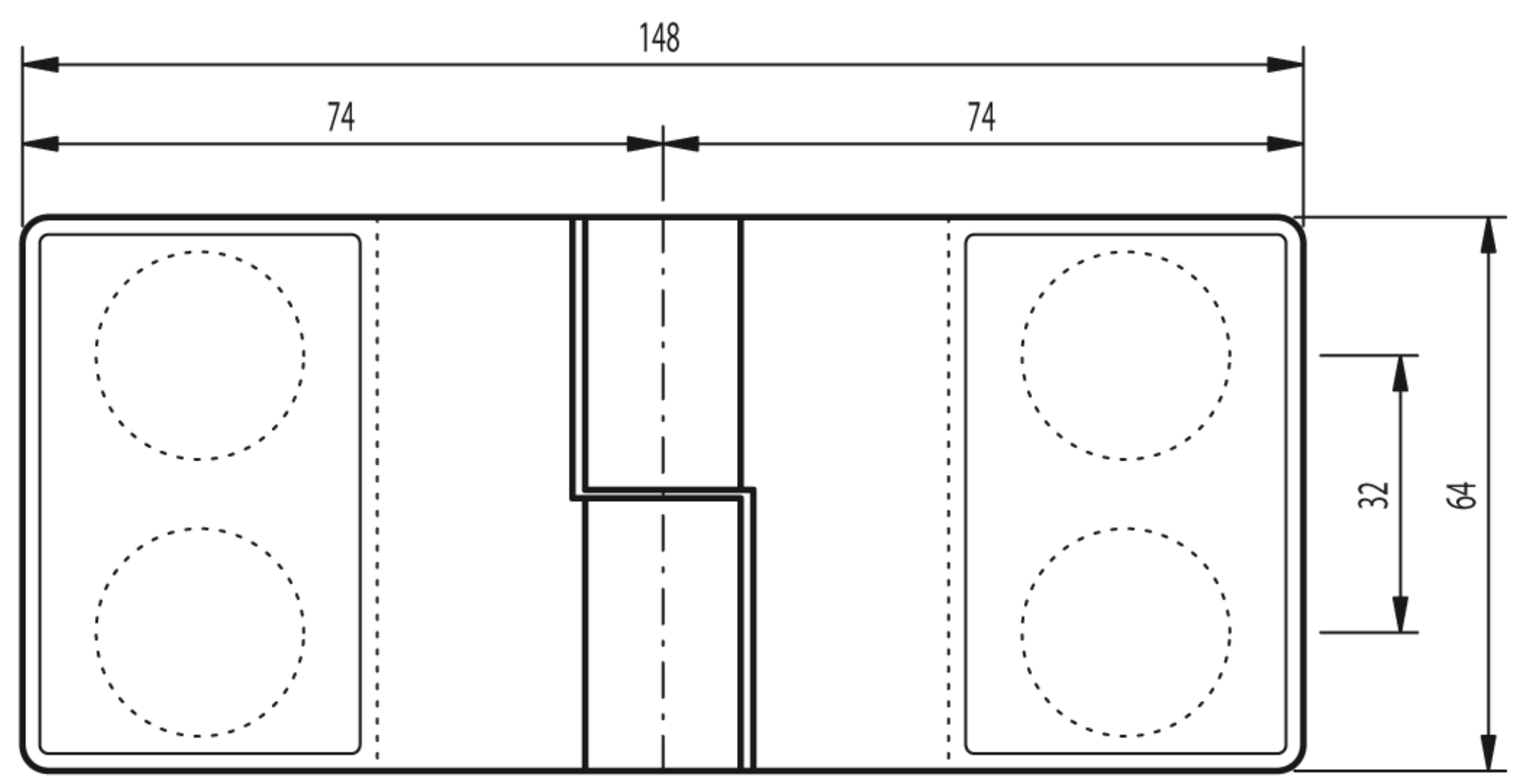
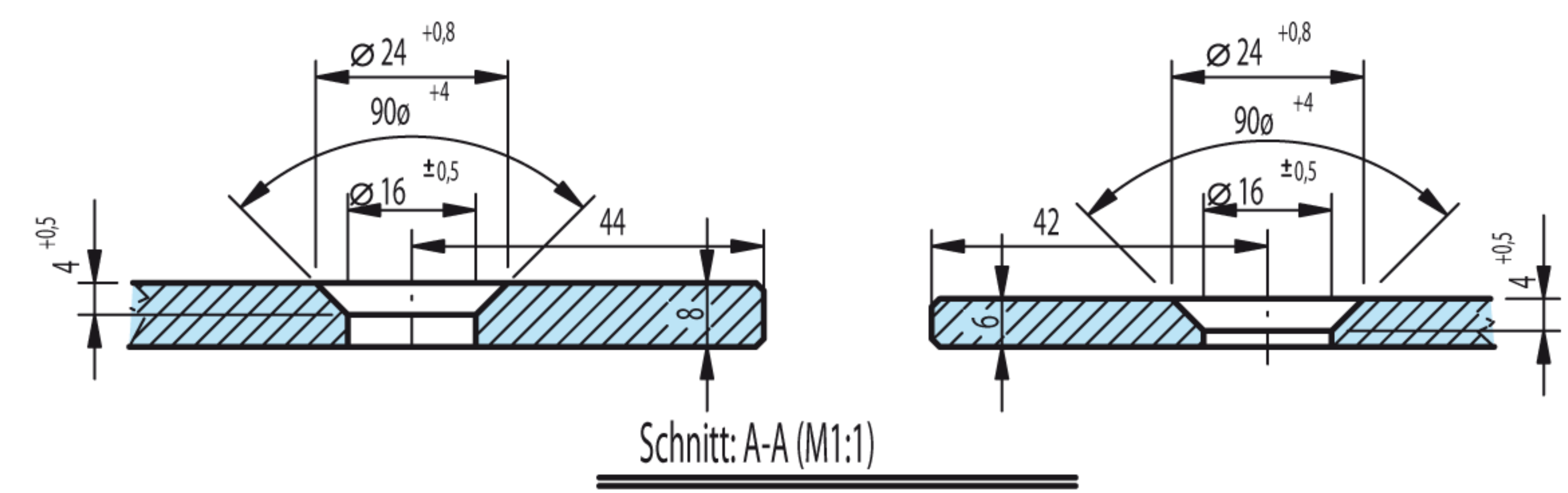

Art.-Nr.: 20 1001 12 XX 00

